

**INVITATION TO BID  
(ITB)**

**LOCH LOMOND NORTH DRAINAGE IMPROVEMENT  
PROJECT**

**ITB No. 2024-19**



**The Town of Miami Lakes Council:**

**Mayor Manny Cid  
Vice Mayor Tony Fernandez  
Councilmember Luis E. Collazo  
Councilmember Josh Dieguez  
Councilmember Ray Garcia  
Councilmember Bryan Morera  
Councilmember Marilyn Ruano**

Edward Pidermann, Town Manager  
The Town of Miami Lakes  
6601 Main Street  
Miami Lakes, Florida 33014

<b>Date Advertised</b>	June 10, 2024
<b>Non-Mandatory Pre-Bid Conference</b>	11:00 AM, June 20, 2024
<b>Bids Due</b>	11:00 AM, July 11, 2024

Loch Lomond North Drainage Improvement Project

ITB 2024-19

**Table of Contents**

**Section A. NOTICE TO BIDDERS..... 5**

**Section B. INSTRUCTIONS TO BIDDERS ..... 7**

B1 DEFINITION OF TERMS ..... 7

B2 BID PROCESS ..... 8

B2.01 GENERAL REQUIREMENTS FOR BID PROCESS ..... 8

B2.02 PREPARATION OF BID ..... 9

B2.03 ESTIMATED QUANTITIES ..... 9

B2.04 LINE-ITEM QUANTITIES ..... 9

B2.05 ADDITIONAL LINE-ITEM PRICING ..... 9

B2.06 BID PREPARATION COSTS AND RELATED COSTS ..... 9

B2.07 PRE-BID CONFERENCE..... 9

B2.08 QUALIFICATION OF BIDDERS..... 10

B2.09 EXAMINATION OF CONTRACT DOCUMENTS ..... 10

B2.10 INTERPRETATIONS AND CLARIFICATIONS..... 10

B2.11 POSTPONEMENT OF BID OPENING DATE ..... 10

B2.12 ACCEPTANCE OR REJECTION OF BIDS ..... 10

B2.13 WITHDRAWAL OF BID ..... 11

B2.14 OPENING OF BIDS ..... 11

B2.15 LOCAL PREFERENCE ..... 11

B2.16 TIE BIDS ..... 11

B2.17 AWARD OF CONTRACT(S) ..... 11

B2.18 BID PROTEST PROCESS..... 11

B2.19 EXECUTION OF CONTRACT..... 12

B2.20 PERFORMANCE & PAYMENT BONDS ..... 12

B3 REQUIRED FORMS & AFFIDAVITS..... 12

B3.01 COLLUSION ..... 12

B3.02 RELATIONSHIPS WITH THE TOWN AFFIDAVIT ..... 12

B3.03 CONFLICT OF INTEREST/ANTI-KICKBACK ..... 12

B3.04 PUBLIC RECORDS AFFIDAVIT .....	12
B3.05 PUBLIC ENTITY CRIMES ACT .....	13
<b>Section C. GENERAL TERMS &amp; CONDITIONS.....</b>	<b>14</b>
C1 GENERAL REQUIREMENTS .....	14
C1.01 GENERALLY .....	14
C1.02 RULES AND REGULATIONS .....	14
C1.03 HOURS FOR PERFORMING WORK.....	14
C1.04 SUBCONTRACTORS.....	14
C1.05 CONSULTANT SERVICES .....	15
C1.06 AUTHORITY OF THE PROJECT MANAGER.....	15
C1.07 INDEPENDENT CONTRACTOR.....	15
C1.08 THIRD-PARTY BENEFICIARIES .....	16
C1.09 ASSIGNMENT OR SALE OF CONTRACT .....	16
C1.10 TIME FOR COMPLETION.....	16
C1.11 APPLICABLE LAW AND VENUE OF LITIGATION.....	16
C1.12 NON-EXCLUSIVE CONTRACT .....	16
C1.13 SEVERABILITY .....	16
C1.14 CONTRACT DOCUMENTS CONTAIN ALL TERMS.....	17
C1.15 ENTIRE AGREEMENT .....	17
C1.16 INTENTION OF THE TOWN .....	17
C1.17 PRIORITY OF PROVISIONS .....	17
C1.18 ROYALTIES AND PATENTS .....	18
C1.19 PURCHASE AND DELIVERY, STORAGE, AND INSTALLATION.....	18
C1.20 PAYMENT OF MATERIALS STORED ONSITE.....	18
C1.21 VEHICLES & EQUIPMENT.....	18
C1.22 OWNERSHIP OF THE WORK .....	18
C1.23 TOWN LICENSES, PERMITS AND FEES.....	18
C1.24 TAXES .....	19
C1.25 REMOVAL OF UNSATISFACTORY PERSONNEL.....	19
C1.26 DEFECTIVE OR NON-COMPLIANT WORK .....	19
C1.27 COMPLIANCE WITH APPLICABLE LAWS .....	20
C1.28 NONDISCRIMINATION, EQUAL EMPLOYMENT OPPORTUNITY, & ADA.....	20

C1.29 NOTICES .....	20
C2 INDEMNITY & INSURANCE .....	21
C2.01 INDEMNIFICATION .....	21
C2.02 CONTRACTOR’S RESPONSIBILITY FOR DAMAGES TO THE WORK .....	21
C2.03 DEFENSE OF CLAIMS .....	21
C2.04 INSURANCE .....	21
C3 PUBLIC RECORDS.....	23
C3.01 ACCESS, REVIEW AND RELEASE OF RECORDS .....	23
C4 CONTRACT MODIFICATION AND DISPUTE PROCESS .....	24
C4.01 CHANGE ORDERS.....	24
C4.02 FORCE MAJEURE .....	25
C4.03 EXTENSION OF TIME .....	25
C4.04 EXCUSABLE DELAY, NON-COMPENSABLE .....	26
C4.05 CLAIMS .....	26
C4.06 CONTINUING THE WORK .....	27
C4.07 FRAUD AND MISREPRESENTATION.....	27
C4.08 STOP WORK ORDER .....	27
C4.09 MATERIALITY AND WAIVER OF BREACH .....	28
C4.10 TIME IN WHICH TO BRING ACTION AGAINST THE TOWN.....	28
C4.11 CONTRACT EXTENSION .....	28
C5 EARLY TERMINATION & DEFAULT .....	28
C5.01 SET-OFFS, WITHOLDING, AND DEDUCTIONS .....	28
C5.02 CONTRACTOR DEFAULT .....	29
C5.03 TERMINATION FOR CONVENIENCE .....	29
C5.04 REMEDIES AVAILABLE TO THE TOWN .....	30
C5.05 FUNDS AVAILABILITY .....	30
C6 PAYMENT PROCESS .....	30
C6.01 COMPENSATION.....	30
C6.02 ESTIMATED QUANTITIES .....	31
C6.03 LINE-ITEM PRICING .....	31
C6.04 LINE-ITEM QUANTITIES .....	31
C6.05 ADDITIONAL LINE-ITEM PRICING .....	31

C6.06 REIMBURSIBLE EXPENSES .....	31
C7 AMERICAN RESCUE PLAN REQUIRED CONTRACTUAL PROVISIONS.....	32
C7.01 EQUAL OPPORTUNITY EMPLOYMENT.....	32
C7.02 COPELAND ANTI-KICKBACK ACT.....	33
C7.03 CONTRACT WORK HOURS AND SAFETY STANDARDS .....	33
C7.04 CLEAN AIR ACT AND THE FEDERAL WATER POLLUTION CONTROL ACT .....	33
C7.05 SUSPENSION AND DEBARMENT.....	33
C7.06 BYRD ANTI-LOBBYING AMENDMENT.....	34
<b>Section D. SPECIAL TERMS &amp; CONDITIONS .....</b>	<b>34</b>
D1 SCOPE OF WORK .....	34
D2 CONTRACT TERM .....	34
D3 COMPENSATION .....	34
D4 SPECIFICATIONS .....	34
D5 LIQUIDATED DAMAGES.....	35
D6 WARRANTY .....	35
D7 SUBSTANTIAL COMPLETION, PUNCHLIST & FINAL COMPLETION .....	35
D8 ACCEPTANCE AND FINAL PAYMENT .....	37
D9 E-VERIFY .....	37
D10 NPDES REQUIREMENTS .....	38
D11 STAGING SITE.....	38
D12 PROJECT HOUSEKEEPING.....	38
<b>Section E. FORMS.....</b>	<b>39</b>
<b>BID FORM .....</b>	<b>40</b>
<b>Certification – Trench Safety Act .....</b>	<b>42</b>
<b>COMPANY QUALIFICATION QUESTIONNAIRE .....</b>	<b>43</b>
<b>CLIENT REFERENCE LETTER .....</b>	<b>49</b>
<b>ADDENDUM ACKNOWLEDGEMENT FORM.....</b>	<b>50</b>
<b>CONTRACT EXECUTION FORM .....</b>	<b>60</b>
<b>CORPORATE RESOLUTION.....</b>	<b>61</b>

## SECTION A. NOTICE TO BIDDERS

**ITB Name:** Loch Lomond North Drainage Improvement Project  
**ITB.No.:** 2024-19  
**Pre-Bid Conference:** 11:00 AM, June 20, 2024  
**Bids Due:** 11:00 AM, July 11, 2024

### **Solicitation Overview:**

The Town of Miami Lakes (the “Town”) will be accepting sealed Bids from qualified firms for the Loch Lomond North Drainage Improvement Project (“Project”). The Town is seeking an experienced contractor with the right combination of price, qualifications, and experience to help ensure that the Town will have a contractor who can bring this Project in on time, within budget and according to the plans and specifications, with a minimum of issues and change orders.

Bidders are to submit one (1) original and two (2) physical copies of their Bid, with original signatures together with one (1) additional virtual copy of the Bid on a Flash Drive. Sealed Bids, including the Flash Drive must be received by the Town of Miami Lakes, Town Clerk at 6601 Main Street, Miami Lakes, Florida **no later than 11:00 AM on July 11, 2024**, at which time the Bids will be opened.

A Non-Mandatory, Pre-Bid Conference is scheduled for 11:00 AM on June 20, 2024, at Town of Miami Lakes Town Hall. It is strongly recommended that potential Bidders attend this meeting. The meeting space has limited capacity, so we request that no more than two representatives from any one company attend the meeting.

### **General Instructions:**

**Bidders must carefully review all the materials contained herein and prepare their Bids accordingly.** The detailed requirements set forth below will be used to evaluate the Bids and failure of a Bidder to provide the information requested for a specific requirement may render their Bid non-responsive and will result in rejection.

Copies of the ITB will only be made available on the Town’s website, Public Purchase, and the Onvia DemandStar (“DemandStar”) website. Copies of the ITB, including all related documents can be obtained by visiting the Town’s website at [Town of Miami Lakes - Growing Beautifully - Current Solicitations \(miamilakes-fl.gov\)](http://Town of Miami Lakes - Growing Beautifully - Current Solicitations (miamilakes-fl.gov)), on Public Purchase at [www.publicpurchase.com](http://www.publicpurchase.com), or on DemandStar’s website at [www.demandstar.com](http://www.demandstar.com). If you use Public Purchase or DemandStar, it is strongly recommended that you register with them to receive notifications about this solicitation.

### **Minimum Requirements to Submit a Response:**

To be eligible for award of this project, bidders must:

1. Possess a minimum of five (5) years of experience performing drainage improvement work of a similar size, scope, and complexity for local and county government agencies.
2. Must have completed at least five (5) drainage improvement projects in the past three (3) years demonstrated through five (5) Form CRL – Client Reference Letters;
3. Possess a valid State of Florida Certified General Contractor license or a Certificate of Competency from the Miami-Dade County’s Construction Trades Qualifying Board as a General Engineering Contractor or as a Specialty Engineering Contractor; and
4. Self-perform at least thirty percent (30%) of multiple trade work.

The Town will consider a Bid as responsive where a Bidder has less than the stipulated minimum number of years of experience solely where the Bidder has undergone a name change and such change of name has been filed with the State of Florida.

Pursuant to subsection (t) “Cone of Silence” of Section 2-11.1 “Conflict of Interest and Code of Ethics Ordinance” of Miami Dade County, public notice is hereby given that a “Cone of Silence” is imposed concerning this solicitation.

The "Cone of Silence" prohibits certain communications concerning the substance of RFP's, RFQ's or Bids, until such time as the Town Manager makes a written recommendation to the Town Council concerning the solicitation. **Any questions concerning the substance of this, or any other solicitation advertised by the Town must be submitted in writing to [procurement@miamilakes-fl.gov](mailto:procurement@miamilakes-fl.gov) while the Cone of Silence is in effect. No other communications, oral or otherwise, will be accepted.** Failure to comply with the Cone of Silence may result in the rejection of a Submittal. For additional information concerning the Cone of Silence please refer to Section 2-11.1 of Miami-Dade County Code.

## SECTION B. INSTRUCTIONS TO BIDDERS

### B1 DEFINITION OF TERMS

1. **Award** means that the Town Manager or Town Council, as applicable, has approved the award of a contract.
2. **Bid** means the Submittal tendered by a Bidder in response to this solicitation, which includes the price, authorized signature and all other information or documentation required by the Invitation to Bid (“ITB”) at the time of submittal.
3. **Bid Form** means the form that contains the goods or services to be purchased and that must be completed and submitted with the Bid.
4. **Bidder** means any person, firm or corporation, or its duly authorized representative tendering a Submittal in response to this solicitation.
5. **Change Order** means a written document ordering a change in the Contract price or Contract time or a material change in the Work.
6. **Completion Time** means the number of calendar days specified for Final Completion of the Project.
7. **Cone of Silence** means the time period and method of communications as required by Section 2-11.1 of the Miami-Dade County Code, which state that the Cone of Silence shall be in effect from the date the ITB is issued until the Town Manager issues a written recommendation.
8. **Consultant** means a firm that has entered into a separate agreement with the Town for the provision of professional services.
9. **Contract** means the ITB, the addendum, and the Bid documents that have been executed by the Bidder and the Town subsequent to approval of award by the Town.
10. **Contract Documents** means the Contract as may be amended from time to time, and plans, specifications, addendum, clarifications, directives, Change Orders, payments, and other such documents issued under or relating to the Contract.
11. **Contractor** means the Successful Bidder who is issued a Purchase Order, Contract, Blanket Purchase Order agreement, or Term Contract to provide goods or services to the Town and who will be responsible for the acceptable performance of any Work and for the payment of all legal debts pertaining to the Work under the Contract.
12. **Cure** means the action taken by the Contractor promptly, after receipt of written notice from the Town of a breach of the Contract Documents, which must be performed at no cost to the Town, to repair, replace, correct, or remedy all material, equipment, or other elements of the Work or the Contract Documents affected by such breach, or to otherwise make good and eliminate such breach.
13. **Cure Period** means the period of time in which the Contractor is required to remedy deficiencies in the Work or compliance with the Contract Documents after receipt of a written Notice to Cure from the Town identifying the deficiencies and the time to Cure.
14. **Days** mean calendar days unless otherwise specifically stated in the Contract Documents.
15. **Defective Work** means (a) Work that is unsatisfactory, deficient, or damaged, does not conform to the Contract Documents, or does not meet the requirements of any inspection, test, or approval, or (b) Work associated with punch list items that the Contractor fails to complete within a reasonable time after issuance of the punch list by the Project Manager.
16. **Design Documents, Plans or Sketch** means any construction plans and specifications, or graphic representation included as part of the Contract.
17. **Division or The Division** means the State of Florida, Division of Emergency Management
18. **Field Directive** means a written directive to effect changes to the Work, issued by the Project Manager, Consultant or the Town Department Director that may affect the ITB Contract price or time.

19. **Final Completion** means the date the Contractor has completed all the Work and submitted all documentation required by the Contract Documents.
20. **Free on Board (F.O.B.)** means the Contractor is solely responsible for the purchase, delivery, off-loading, and installation of all equipment and material(s) and assumes all liability for replacement of any damaged equipment or material(s) and filing any and all claims with suppliers.
21. **Inspector** means an authorized representative of the Town assigned to make necessary inspections of materials furnished by Design-Build Firm and of the Work performed by the Contractor. The Town, at its sole discretion, may hire a professional consultant to perform the inspections.
22. **Materials** mean goods or equipment incorporated into the Work or used or consumed in the performance of the Work.
23. **Notice of Award** means any correspondence from the Town that informs the successful bidder of a contract award for this ITB.
24. **Project** means a task or series of tasks that the Contractor must complete in accordance with the Contract Documents.
25. **Project Manager** means the individual assigned by the Town Manager or designee to manage a Project.
26. **Request for Information (RFI)** means a request from the Contractor seeking an interpretation or clarification relative to the Contract Documents. The RFI, which must be clearly marked RFI, must clearly and concisely set forth the issue(s) or item(s) requiring clarification or interpretation and why the response is required. The RFI must set forth the Contractor's interpretation or understanding of the document(s) in question, along with the reason for such understanding.
27. **Responsive Bidder** means the Bidder whose Bid conforms in all material respects to the terms and conditions included in the ITB.
28. **Responsible Bidder** means a Bidder who has the capability in all respects to perform in full the contract requirements, as stated in the ITB, and integrity and reliability that will assure good faith performance.
29. **Subcontractor** means a person, firm or corporation having a direct contract with Contractor, including one who furnishes material, equipment, or services necessary to perform the Work.
30. **Submittal** means the documents prepared and submitted by the Bidder in response to this ITB.
31. **Substantial Completion** means that point at which the Project is at a level of completion in substantial compliance with the Contract Documents and is fit for use in its intended purpose. Substantial Compliance will not be deemed to have occurred until any and all governmental entities, with regulatory authority or which have jurisdiction over the Work, have conducted all final inspections, and approved the Work. Beneficial use or occupancy will not be the sole factor in determining whether Substantial Completion has been achieved unless a temporary certificate of completion has been issued.
32. **Town** means the Town Council of the Town of Miami Lakes or the Town Manager, as applicable.
33. **Town Manager** means the duly appointed chief administrative officer of the Town of Miami Lakes or designee.
34. **Unbalanced Bid** means pricing that is not consistent with pricing in the industry or with market conditions and a comparison to the pricing submitted by other Bidders.
35. **Work** as used herein refers to all reasonably necessary and inferable labor, material, equipment, and services, whether or not specifically stated, to be provided by the Contractor to fulfill its obligations under the Contract Documents.

## **B2 BID PROCESS**

### **B2.01 GENERAL REQUIREMENTS FOR BID PROCESS**

The ITB, Bid Form and any addendum that may be issued constitute the complete set of requirements for this ITB. The Bid Form page(s), and all forms contained in the ITB must be completed, signed, and submitted in

accordance with the requirements of Section B. All Bids must be typewritten or filled in with pen and ink and must be signed in blue ink by an officer or employee having authority to bind the company or firm. Errors, corrections, or changes on any document must be initialed by the signatory of the Bid. Bidder will not be allowed to modify its Bid after the opening time and date.

(i) *Joint Venture or Teaming Agreements*

Joint venture firms or teaming agreements will not be considered for award under this ITB.

**B2.02 PREPARATION OF BID**

The Bid Form contains multiple line-items, and the Bidder must provide prices for all line-items and must provide the price for the total Bid amount. Failure to include pricing on all line-items as well as the total Bid Amount will result in the Bid being found non-responsive.

**Bidder must use the blank Town forms provided herein.** The Bid must be signed and acknowledged by the Bidder in accordance with the directions within this ITB. Failure to utilize or fully complete the Town's forms may result in a determination that the Bid is non-responsive.

A Bid will be considered non-responsive if it is conditioned on modifications, changes, or revisions to the terms and conditions of the ITB.

All Bid prices are to include the furnishing of all labor, materials, equipment, all overhead/indirect expenses, and profit, necessary for the completion of the Work, except as may be otherwise expressly provided for in the Contract Documents.

**B2.03 ESTIMATED QUANTITIES**

The quantities stated on the Bid Form are solely estimates of what the Town anticipates its needs are for the initial year of the Contract. The stated quantities do not reflect the actual quantities to be ordered and the Town has not established any minimum quantities and no guarantee is expressed or implied as to the total quantity of Work to be issued to a Contractor. The Town reserves the right, at its sole discretion, to make adjustment to the number and/or location of the Bid items. The failure of the Town to order any minimum quantities does not form any basis for a claim by the Contractor for lost work or profits.

**B2.04 LINE-ITEM QUANTITIES**

The estimated quantities will be used solely for bid comparison purposes for the Town to determine the lowest responsive and responsible. No guarantee is expressed or implied as to the total quantity of Work to be issued to a Contractor.

**B2.05 ADDITIONAL LINE-ITEM PRICING**

The Town reserves the right to request price quotes for additional items not contained in the initial award. Should the Town add any additional line-items the Town will do so through the Change Order process.

**B2.06 BID PREPARATION COSTS AND RELATED COSTS**

All costs involved in the preparation and submission of a Bid to the Town, or any work performed in connection therewith is the sole responsibility of the Bidder(s). No payment will be made for any Bid received, or for any other effort required of or made by the Bidder prior to commencement of Work as defined by any contract duly approved by the Town Council or Town Manager. The Town will bear no responsibility for any cost associated with any judicial proceedings resulting from the ITB process.

**B2.07 PRE-BID CONFERENCE**

A non-mandatory pre-bid conference will be held in the Community Conference Room at the Government Center, 6601 Main Street, Miami Lakes, FL 33014 at 11:00 AM on Thursday, June 20, 2024.

**B2.08 QUALIFICATION OF BIDDERS**

Bidder, by virtue of submitting its Bid, certifies that it is qualified and capable of performing the Work required under the Contract. To qualify for award, Bidder must meet the minimum qualification requirements stated in Section A. Bidders must complete the attached Questionnaire Form and include it with their Bid. Failure to complete and submit this form or to meet the minimum qualifications will result in the Bid being deemed non-responsive. The Town may at its sole discretion allow a Bidder to amend an incomplete Questionnaire during the evaluation process provided that the Bidder has included the Questionnaire in its Bid.

**B2.09 EXAMINATION OF CONTRACT DOCUMENTS**

It is the responsibility of each Bidder, before submitting a Bid in response to this ITB to:

- a. Carefully review the ITB, including any Addendum and notify the Town of any conflicts, errors, or discrepancies.
- b. Take into account federal, state and local, including, without limitation, the Town’s Code, and Miami-Dade County and the State of Florida’s statutes laws, rules, regulations, and ordinances that may affect a Bidder’s ability to perform the Work.
- c. Study and carefully correlate Contractor's observations with the requirements of the ITB.

The submission of a Bid in response to this solicitation constitutes an incontrovertible representation by Bidder that it will comply with the requirements of the Contract Documents and that without exception, the Bid is premised upon performing and furnishing the Work required under the Contract Documents and that the Contract Documents are sufficient in detail to indicate and convey understanding of all terms and conditions for the performance of the Work.

**B2.10 INTERPRETATIONS AND CLARIFICATIONS**

All questions about the meaning or intent of the ITB, must be directed in writing and submitted by e-mail to the Procurement Office, at [procurement@miamilakes-fl.gov](mailto:procurement@miamilakes-fl.gov). Interpretation or clarifications considered necessary by the Town in response to such questions will be issued by means of an addendum. All addenda will be posted on the Town’s website, Public Purchase, and DemandStar. It is the sole responsibility of the Bidder to obtain all addenda by visiting the Town’s website. Written questions must be received no less than ten (10) days prior to bid opening. Only questions answered by written addenda will be binding. Verbal interpretation or clarifications will be without legal effect.

**B2.11 POSTPONEMENT OF BID OPENING DATE**

The Town reserves the right to postpone the date for receipt and opening of Bids and will make a reasonable effort to give at least five (5) calendar days’ notice prior to the Bid opening date of any such postponement to prospective Bidders. Any such postponement will be announced through the issuance of an addendum posted to the Town’s website.

**B2.12 ACCEPTANCE OR REJECTION OF BIDS**

The Town reserves the right to reject any and all Bids, with or without cause, to waive technical errors and informalities, or to cancel or re-issue this solicitation. The Town also reserves the right to reject the Bid of any Bidder who has failed to previously perform under a contract or who is in arrears to the Town.

*(i) Unbalanced Bids*

The Town reserves the right to reject any Bid where the line-item pricing is determined to be unbalanced. Such determination will be made at the sole discretion of the Town. An Unbalanced Bid price, which will be determined at the sole discretion of the Town, includes, but is not limited to, pricing that is not consistent with pricing in the industry or with market conditions and a comparison to the pricing submitted by other Bidders. An Unbalanced Bid typically occurs where the prices for one or more-line items are too low a price

to cover the actual cost to perform the Work (including overhead and profit) or too high a price where excessive profit will occur.

#### B2.13 WITHDRAWAL OF BID

Bidder warrants, by virtue of bidding, that its Bid and the prices quoted in its Bid are firm and irrevocable for acceptance by the Town for a period of one hundred twenty (120) calendar days from the date of the Bid submittal deadline. Bidder may change or withdraw its Bid prior to the Bid submittal deadline. All changes or withdrawals must be made in writing to the Town Clerk. Oral/Verbal modifications will not be valid. Once the Town makes an Award, the Bid cannot be withdrawn.

#### B2.14 OPENING OF BIDS

Bids will be publicly opened at the appointed time and place stated in the ITB and the names of the Bidders will be announced. The Town at its sole option may read the Bid prices. Late Bids will not be opened. Town staff is not responsible for the premature opening of a Bid if the Bid is not properly sealed, addressed, and labeled. Bidders or their authorized agents are invited to be present at the Bid opening. Any additional information on the Bid Submittals will be made available in accordance with Florida Statute 119.071, Paragraph (b) of subsection (1), item 2, as amended. Review of the Bid Submittals by Town staff will determine the lowest responsive and responsible Bidder(s).

#### B2.15 LOCAL PREFERENCE

This ITB is subject to local preference under Section 13 of Town Ordinance 17-203. In order to qualify, Bidders seeking preference must submit the Local Vendor Preference Certification Form with all required supporting documentation. The Local Vendor Preference Certification Form can be found on the Town's website at [Town of Miami Lakes - Growing Beautifully - Local Preference \(miamilakes-fl.gov\)](http://Town of Miami Lakes - Growing Beautifully - Local Preference (miamilakes-fl.gov)).

#### B2.16 TIE BIDS

Preference shall be given to businesses with Drug-Free Workplace programs. Whenever two (2) or more bids which are equal in price, the Award will be determined in accordance with Florida Statute 287.133(2)(a), the Drug-Free Workplace Act. Where tie Bids still exist, the Award will be made to one of the Bidders at the sole discretion of the Town Manager.

#### B2.17 AWARD OF CONTRACT(S)

The Town anticipates awarding a contract to the lowest responsive and responsible Bidder(s) that is in the best interest of the Town.

The Town may require demonstration of competency and, at its sole discretion, conduct site visit(s) and inspections of the Bidder's place of business, require the Bidder to furnish documentation or require the Bidder to attend a meeting to determine the Bidder's qualifications and ability to meet the terms and conditions of this Contract. The Town will consider, but not be limited to, such factors as financial capability, labor force, equipment, experience, knowledge of the trade work to be performed, the quantity of Work being performed by the Contractor and past performance on Town and other contracts. In no case will the Award be made until all necessary investigations have been made into the responsibility of the Bidder and the Town is satisfied that the Bidder(s) is qualified to perform the Work.

#### B2.18 BID PROTEST PROCESS

Any Bidder wishing to file a protest as to the requirements or award of this ITB must do so in accordance with Town Ordinance 17-203, Section 16, which is available at [Town of Miami Lakes - Growing Beautifully - Home \(miamilakes-fl.gov\)](http://Town of Miami Lakes - Growing Beautifully - Home (miamilakes-fl.gov)).

### **B2.19 EXECUTION OF CONTRACT**

The Successful Bidder must, within fourteen (14) calendar days after receiving a Notice of Award, sign and deliver to the Town the Contract Execution and Certificate of Authority forms found in Section E, together with the acceptable bonds as required in Article B2.20, Performance & Payment Bonds, below.

### **B2.20 PERFORMANCE & PAYMENT BONDS**

The Successful Bidder must, within fourteen (14) calendar days after receiving a Notice of Award, submit a performance and payment bond ("Bond") using the attached Performance Bond forms in the amount of the contract value. The Bond will guarantee the completion of the Work covered by the Contract Documents as well as the payment of all suppliers, Subcontractors, and the Contractor's workforce. The Bond(s) shall not contain a provision allowing the Surety(ies) to cancel the Bonds prior to the completion of the Contract, including the option to renew years.

The Bond must be executed by a surety company of recognized standing, authorized to do business in the State of Florida as a surety.

## **B3 REQUIRED FORMS & AFFIDAVITS**

### **B3.01 COLLUSION**

Where two (2) or more related parties, as defined in this Article, each submit a response to an ITB, such submissions will be presumed to be collusive. The foregoing presumption may be rebutted by the presentation of evidence as to the extent of ownership, control, and management of such related parties in preparation and submission under such ITB. Related parties mean employees, officers or the principals thereof which have a direct or indirect ownership interest in another firm or in which a parent company or the principals thereof of one Bidder have a direct or indirect ownership interest in another Bidder for the same project. ITB responses found to be collusive will be rejected. Bids must be developed independently. Where two or more Bidders have worked together, discussed the details of their bids prior to submission of their Bids or worked together in independently submitting Bids such actions will be deemed to be collusion.

### **B3.02 RELATIONSHIPS WITH THE TOWN AFFIDAVIT**

The Bidder must identify any relationship the owners or employees have with the Town's elected officials or staff using the Relationships with the Town affidavit found in Section E, Forms.

### **B3.03 CONFLICT OF INTEREST/ANTI-KICKBACK**

Bidder must complete and submit the Conflict of Interest, Anti-Kickback and Proposer's Relationships to the Town Affidavits found in Section E, Forms, in its Bid. Bidder certifies that its Bid is made independently of any assistance or participation from any Town employee, elected official, or contractor working for or on behalf of the Town, who assisted in any aspect with the development, evaluation, or award if this or any solicitation issued by the Town.

Town employees may not contract with the Town through any corporation, or business entity in which they or their immediate family members hold a controlling financial interest (e.g., ownership of five (5) percent or more). Immediate family members, including spouse, parents, and children are also prohibited from contracting with the Town without the prior approval of the Town Council.

Miami-Dade County Ordinance 2-11.1, Conflict of Interest & Code of Ethics ordinance or the provisions of Chapter 112, Part III, Fla. Stat., Code of Ethics for Public Officers, and Employees, as applicable and as amended are hereby included into and made a part of this solicitation.

### **B3.04 PUBLIC RECORDS AFFIDAVIT**

The Town shall comply with the Public Records Law as provided by Chapter 119, Florida Statutes, and all applicable amendments. Applicants must invoke the exemptions to disclosure provided by law in the response

to the solicitation and must identify the data or other materials to be protected by separate envelope and must state the reasons why such exclusion from public disclosure is necessary. The submission of a response authorizes release of your firm's credit data to the Town.

All prospective Bidders must complete and submit the Compliance with Public Records Law affidavit with their Bid. Failure to submit the completed affidavit may result in the Bid being deemed non-responsive. Bidders, by submitting the Compliance with Public Records Law affidavit, specifically acknowledge their obligation to comply with Section 119.0701, Florida Statutes.

**B3.05 PUBLIC ENTITY CRIMES ACT**

In accordance with the Public Entity Crimes Act, (Section 287.133, Florida Statutes) a person or affiliate who is a contractor, who had been placed on the convicted vendor list following a conviction for a public entity crime may not submit a bid on a contract to provide any goods or services to the Town, may not submit a bid on a contract with a public entity for the construction or repair of a public building or public work, may not submit bids on leases or real property to the Town, may not be awarded or perform work as a contractor, supplier, subcontractor, or consultant under a contract with any public entity, and may not transact business with the Town in excess of the threshold amount provided in Section 287.917, Florida Statutes, for Category Two for a period of 36 months from the date of being placed on the convicted vendor list. Violation of this section by the Contractor will result in rejection of the Bid, termination of the contract, and may cause Contractor debarment.

**END OF SECTION**

## SECTION C. GENERAL TERMS & CONDITIONS

### C1 GENERAL REQUIREMENTS

#### C1.01 GENERALLY

The employee(s) of the Contractor will be considered to be at all times its employee(s), and not employee(s) or agent(s) of the Town or any of its departments.

The Contractor agrees that the Contractor will at all times employ, maintain and assign to the performance of the Contract a sufficient number of competent and qualified professionals and other personnel to meet the requirements of the Work to be performed.

The Contractor agrees to adjust staffing levels or to replace any staff personnel if so requested by the Town Manager or designee, should the Town Manager or designee make a determination that said staffing is unacceptable or that any individual is not performing in a manner consistent with the requirements for such a position.

The Contractor represents that its staff personnel have the proper skills, training, background, knowledge, experience, rights, authorizations, integrity, character, and licenses necessary to perform the Work, in a competent and professional manner.

The Contractor must at all times cooperate with the Town, or the Consultant (if any) and coordinate its respective Work efforts to most effectively and efficiently progress the performance of the Work.

The Town, the Consultant (if any) and other agencies authorized by the Town, must have full access to the Project site at all times.

The apparent silence of the Contract Documents as to any detail, or the apparent omission from them of a detailed description concerning any Work to be done and materials to be furnished, will be regarded as meaning that only best practices are to prevail and only materials and workmanship of the best quality are to be used in the performance of the Work.

#### C1.02 RULES AND REGULATIONS

The Contractor must comply with all laws and regulations applicable to provision of services specified in the Contract Documents. The Contractor must be familiar with all federal, state, and local laws, rules, regulations, codes, and ordinances that affect the Work.

Where portions of the Work traverse or cross federal, state, county or local highways, roads, streets, or waterways, and the agency in control of such property has established standard specifications, rules or regulations governing items of Work that differ from these specifications, the most stringent specifications, rules, and regulations will apply.

#### C1.03 HOURS FOR PERFORMING WORK

All Work must be performed in accordance with the Town's Noise Ordinance No. 04-50 unless specifically stated otherwise herein or in a Work Order. Work to be performed outside these hours will require the prior written approval of the Project Manager.

#### C1.04 SUBCONTRACTORS

Contractor is solely responsible for all acts and omissions of its Subcontractors. Nothing in the Contract Documents creates any contractual relationship between any Subcontractor and the Town. Contractor is responsible for the timely payment of its Subcontractors and suppliers as required by Florida Statute Chapter 218.735. Failure to comply with these payment requirements will place the Contractor in default of the Contract.

Contractor must not employ any subcontractor against whom Town may have a reasonable objection.

Contractor must utilize the Subcontractors identified in its Bid submission. The replacement, addition, or deletion of any Subcontractor(s) will be subject to the prior written approval of the Project Manager.

Bidders that will be using a temporary labor company to provide staffing for the Project must complete the Leased Employees Affidavit Form and include it with their Bid. Failure to include this form may result in the Bid being rejected as non-responsive.

#### C1.05 CONSULTANT SERVICES

The Town, at its sole discretion, may hire a Consultant who may serve as the Town's representative for the Contract. Where a Consultant has been identified, the Consultant and the Project Manager will both have authority to act on behalf of the Town to the extent provided for in the Contract Documents, and where such authority has been delegated in writing by the Town Manager.

#### C1.06 AUTHORITY OF THE PROJECT MANAGER

The Town Manager hereby authorizes the Project Manager to determine, all questions of any nature whatsoever arising out of, under or in connection with, or in any way relating to or on account of the Work, and questions as to the interpretation of the Work to be performed under the Contract Documents. The Project Manager may delegate some of the authority contained in this Article to a designee.

The Contractor is bound by all determinations or orders of the Project Manager and must promptly respond to requests of the Project Manager, including the withdrawal or modification of any previous order, and regardless of whether the Contractor agrees with the Project Manager's determination or requests. Where requests are made orally, the Project Manager will follow up in writing, as soon thereafter as is practicable.

The Project Manager and/or designee shall have authority to act on behalf of the Town to the extent provided for by the Contract Documents, unless otherwise modified in writing by the Town. All instructions to the Contractor will be issued in writing through the Town Manager, Project Manager, or designee.

The Project Manager will not be responsible for the means, methods, techniques, sequences, or procedures employed, or for safety precautions and programs in connection with the Work and will not be responsible for the Contractor's failure to carry out the Work in accordance with the Contract Documents.

All interpretations and recommendations of the Project Manager and Consultant will be consistent with the intent of the Contract Documents.

Interpretation of the Contract terms and conditions will be issued by the Town's Procurement Manager.

The Project Manager and/or designee will have authority to reject Work that does not conform to the Contract Documents. Whenever, in their opinion, it is considered necessary or advisable to ensure the proper completion of the Work the Project Manager or Consultant have authority to require special inspections or testing of the Work, whether or not such Work is fabricated, installed or completed.

The Project Manager's authority to act under this paragraph, or any decision made in good faith either to exercise or not to exercise such authority, shall not give rise to any duty or responsibility of the Project Manager owed to the Contractor, any subcontractor, supplier or any of their agents, employees, or any other person performing any of the Work.

The Project Manager is not responsible for the acts or omissions of the Contractor, any Subcontractor, or any of their agents or employees, or any other persons performing any of the Work.

#### C1.07 INDEPENDENT CONTRACTOR

The Contractor is engaged as an independent business and agrees to perform Work as an independent contractor. In accordance with the status of an independent contractor, the Contractor covenants and agrees

that the Contractor will conduct business in a manner consistent with that status, that the Contractor will not claim to be an officer or employee of the Town for any right or privilege applicable to an officer or employee of the Town, including, but not limited to worker’s compensation coverage; unemployment insurance benefits; social security coverage; retirement membership, or credit.

**C1.08 THIRD-PARTY BENEFICIARIES**

Neither Contractor nor Town intends to directly or substantially benefit a third party by this Contract. Therefore, the parties agree that there are no third-party beneficiaries to this Contract and that no third party will be entitled to assert a claim against either of them based upon this Contract.

**C1.09 ASSIGNMENT OR SALE OF CONTRACT**

The performance of this Contract will not be transferred pledged, sold, delegated, or assigned, in whole or in part, by the Contractor without the prior written consent of the Town. It is understood that a sale of the majority of the stock or partnership shares of the Contractor, a merger or bulk sale, an assignment for the benefit of creditors will each be deemed transactions that would constitute an assignment or sale hereunder. The Town may request any information it deems necessary to review any request for assignment or sale of the Contract.

The Contractor must notify the Project Manager prior to any Assignment of the Contract, which must be approved by the Town for the transfer of the Contract. The Town may, at its sole discretion, elect not to approve the transfer of the Contract, which will result in the Contract being terminated in accordance with the Termination for Convenience provision of the Contract. Any transfer without Town approval will be cause for the Town to terminate this Contract for default and the Contractor will have no recourse from such termination.

Nothing herein will either restrict the right of the Contractor to assign monies due to, or to become due or be construed to hinder, prevent, or affect any assignment by the Contractor for the benefit of its creditors, made pursuant to applicable law.

**C1.10 TIME FOR COMPLETION**

Time is of the essence with regard to completion of the Work to be performed under the Contract. Delays and extensions of time may be allowed only in accordance with the provisions of the Contract. The time allowed for completion is provided for in the Special Terms & Conditions.

**C1.11 APPLICABLE LAW AND VENUE OF LITIGATION**

This Contract will be enforceable in Miami-Dade County, Florida, and if legal action is necessary by either party with respect to the enforcement of any or all of the terms or conditions the sole venue will be Miami-Dade County, Florida.

**C1.12 NON-EXCLUSIVE CONTRACT**

This Contract shall not be deemed to create an exclusive relationship between the Town and the Contractor(s). The Town, in its sole discretion, reserves the right to perform, solicit or employ other parties or its own staff to perform Work or Services comparable to those covered herein.

**C1.13 SEVERABILITY**

In the event any provision of the Contract Documents is determined by a Court of competent jurisdiction to be illegal or unenforceable, then such unenforceable or unlawful provision will be excised from this Contract, and the remainder of the Contract Documents will continue in full force and effect. Notwithstanding the foregoing, if the result of the deletion of such provision will materially and adversely affect the rights of either party, such party may elect, at its option, to terminate the Contract in its entirety. An election to terminate

the Contract based upon this provision must be made within seven (7) calendar days after the finding by the Court becomes final.

#### C1.14 CONTRACT DOCUMENTS CONTAIN ALL TERMS

The Contract Documents and all documents incorporated herein by reference contain all the terms and conditions agreed upon by the parties hereto, and no other agreement, oral or otherwise, regarding the subject matter of the Contract Documents will be deemed to exist or to bind any of the parties hereto, or to vary any of the terms contained herein.

#### C1.15 ENTIRE AGREEMENT

The Contract Documents, as they may be amended from time to time, represent the entire and integrated Contract between the Town and the Contractor and supersede all prior negotiations, representations, or agreements, written or oral. This Contract may not be amended, changed, modified, or otherwise altered in any respect, at any time after the execution hereof, except by a written document executed with the same formality and equal dignity herewith. Waiver by either party of a breach of any provision of the Contract Documents will not be deemed to be a waiver of any other breach of any provision of the Contract Documents.

#### C1.16 INTENTION OF THE TOWN

It is the intent of the Town to describe in the ITB the Work to be completed in accordance with all codes and regulations governing all the Work to be performed under this Contract. Any work, labor, materials and/or equipment that may reasonably be inferred from the Contract as being required to produce the intended results must be supplied by Contractor whether or not specifically called for in the Contract Documents. Where words, which have well-known technical or trade meanings are used to describe Work, materials or equipment, such words will be interpreted in accordance with that meaning. Reference to standard specifications, manuals, or codes of any technical society, organization, or association, or to the laws or regulations of any governmental authority, whether such reference be specific or by implication, will mean the latest standard specification, manual, code or laws or regulations in effect at the time of opening of Bids and Contractor must comply therewith. Town will have no duties other than those duties and obligations expressly set forth within the Contract Documents.

#### C1.17 PRIORITY OF PROVISIONS

If there is a conflict or inconsistency between any term, statement requirement, or provision of any exhibit attached hereto, any document or events referred to herein, or any document incorporated into the Contract Documents by reference and a term, statement, requirement, the specifications or any plans, or provision of the Contract Documents the following order of precedence will apply:

1. In the event of conflicts in the Contract Documents the priorities stated below will govern;
2. Revisions and Change Orders to the Contract will govern over the Contract;
3. The Contract Documents will govern over the Contract;
4. The Special Conditions will govern over the General Conditions of the Contract; and
5. Addendum to an ITB will govern over the ITB.

In the event that Drawings and specifications are provided with the Contract the priorities stated below will govern:

1. Scope of Work and Specifications will govern over Plans and Drawings;
2. Schedules, when identified as such will govern over all other portions of the Plans;
3. Specific notes will govern over all other notes, and all other portions of the Plans, unless specifically stated otherwise;
4. Larger scale drawings will govern over smaller scale drawings;
5. Figured or numerical dimensions will govern over dimensions obtained by scaling; and

6. Where provisions of codes, manufacturer's specifications or industry standards are in conflict, the more restrictive, strict, or higher quality will govern.

#### C1.18 ROYALTIES AND PATENTS

All fees, royalties, and claims for any invention, or pretended inventions, or patent of any article, material, arrangement, appliance, or method that may be used upon or in any manner be connected with the Work or appurtenances, are hereby included in the prices stipulated in the Contract for said Work.

#### C1.19 PURCHASE AND DELIVERY, STORAGE, AND INSTALLATION

All materials must be F.O.B. delivered and included in the cost of the Work. The Contractor is solely responsible for the purchase, delivery, off-loading and installation of all equipment and material(s). Contractor must make all arrangement for delivery. Contractor is liable for replacing any damaged equipment or material(s) and filing any and all claims with suppliers. All transportation must comply with all Federal, State of Florida, Miami-Dade County, and Town rules and regulations.

No materials will be stored on site without prior written approval by the Town. Requests for material storage shall be done using the appropriate Town form by the Project Manager. The Town's Forms are available on the Town's website.

#### C1.20 PAYMENT OF MATERIALS STORED ONSITE

The Town may pay for materials stored onsite upon request by the Contractor, and Town approval. Unless otherwise provided in the Contract Documents, applications for payment may include materials and equipment not yet incorporated in the Work, but where delivery has been completed and are suitably stored on the worksite. Approval of payment applications for such stored items on the worksite shall be conditioned upon submission by the Contractor of bills of sale and required insurance, or such other procedures to establish owner's title to such materials and equipment, or otherwise to protect owner's interest which are satisfactory to the Town. When payment for materials stored is permitted, Contractor must submit a separate Schedule for Materials Stored showing line-item, description, previous value received, value incorporated into the Work and present value.

#### C1.21 VEHICLES & EQUIPMENT

Contractor must have on hand at all times clean and in good working order such vehicles, machinery, tools, accessories, and other items necessary to perform the Work under this Contract. The Town may require the repair or replacement of equipment as reasonably necessary.

#### C1.22 OWNERSHIP OF THE WORK

The Contractor is solely responsible for all Work, until Final Completion of the Work. Contractor is liable for all damage, theft, maintenance, and safety until such time as the Town issues a notice of Final Completion of the Work.

#### C1.23 TOWN LICENSES, PERMITS AND FEES

In accordance with the Public Bid Disclosure Act, 218.80, Florida Statutes, each license, permit, or fee the Contractor will have to pay the Town before or during the Work or the percentage method or unit method of all licenses, permits and fees required by the Town and payable to the Town by virtue of the Work as part of the Contract are as follows:

1. Contractor must have and maintain during the term of this Contract all appropriate Town licenses. Fees for which must be paid in full in accordance with the Town's Fee structure for such licenses. THERE WILL NOT BE ANY PERCENTAGE REDUCTION OR WAIVING OF TOWN LICENSE FEES.
2. During the performance of this Contract there may be times when the Contractor will be required to obtain a Town permit for such Work. It is the responsibility of the Contractor to ensure that he has the appropriate

Town permits to perform such work as may become necessary during the performance of the Work. Any fees related to Town required permits in connection with this Contract will be the responsibility of the Contractor and will be reimbursed by the Town.

Licenses, permits, and fees that may be required by County, State or Federal entities are not included in the above list.

#### C1.24 TAXES

Contractor must pay all applicable sales, consumer, use, and other taxes required by law. Contractor is responsible for reviewing the pertinent state statutes involving state taxes and complying with all requirements.

Contractor shall include all sales and other taxes for which it is liable in its Bid price.

#### C1.25 REMOVAL OF UNSATISFACTORY PERSONNEL

Contractor must at all times enforce strict discipline and good order among its employees and subcontractors at the Project(s) site(s) and must not employ on any Work any unfit person or anyone not skilled in the Work to which they are assigned.

The Town may make written request to the Contractor for the prompt removal and replacement of any personnel employed or retained by the Contractor, or any or Subcontractor engaged by the Contractor to provide and perform services or Work pursuant to the requirements of the Contract Documents. The Contractor must respond to the Town within five (5) calendar days of receipt of such request with either the removal and replacement of such personnel or written justification as to why that may not occur. The Town will make the final determination as to the removal of unsatisfactory personnel from the Work. The Contractor agrees that the removal of any of such individual(s) does not require the termination or demotion of said individual(s).

#### C1.26 DEFECTIVE OR NON-COMPLIANT WORK

The Project Manager has the authority to reject or disapprove Work that is found to be defective or not in compliance with the requirements of the Contract. If required, the Contractor will promptly either correct all defective or non-compliant Work or remove such defective Work and replace it with non-defective/non-compliant Work. Contractor will bear all direct, indirect, and consequential costs of such removal or corrections.

Re-examination of any of the Work may be ordered by the Project Manager and if so ordered, the Work must be uncovered by Contractor. If such Work is found to be in accordance with the Contract Documents, the Town will pay the cost of reexamination and replacement by means of a Change Order. If such Work is not in accordance with the Contract Documents, Contractor will pay such cost.

Should Contractor fail or refuse to remove or correct any defective or non-compliant Work or to make any necessary repairs in accordance with the requirements of the Contract Documents within the time indicated in writing by the Project Manager, the Project Manager has the authority to cause the defective/non-compliant Work to be removed or corrected or make such repairs or corrections as may be necessary at Contractor's expense. Any expense incurred by the Town in making such removals, corrections, or repairs, will be paid for out of any monies due or which may become due the Contractor. In the event of failure of the Contractor to make all necessary repairs promptly and fully, the Town Manager or designee may declare the Contractor in default.

If, within the warranty period required by the Contract Documents, or by any specific provision of the Contract, any of the Work is found to be defective or not in accordance with the Contract Documents, Contractor, after receipt of written notice from Town, must promptly correct such defective or nonconforming Work within the time specified by Town, without cost to Town. Should the Contractor fail to take such action the Town may

take any necessary and appropriate action and hold the Contractor liable and responsible for all costs. The Town may take any action allowed under this Contract or in law to recover all such costs. Nothing contained herein will be construed to establish a period of limitation with respect to any other obligation which Contractor might have under the Contract Documents, including but not limited to, any claim regarding latent defects.

Failure to reject any defective Work or material does not, in any way, prevent later rejection when such defect is discovered, or obligate the Town to accept the defective Work.

**C1.27 COMPLIANCE WITH APPLICABLE LAWS**

The Contractor must comply with the most recent editions and requirements of all applicable laws, rule, regulations, codes, and ordinances of the Federal government, the State of Florida, Miami-Dade County, and the Town.

**C1.28 NONDISCRIMINATION, EQUAL EMPLOYMENT OPPORTUNITY, & ADA**

Contractor will not unlawfully discriminate against any person, will provide equal opportunities for employment, and comply with all applicable provisions of the Americans with Disabilities Act in its performance of the Work under the Contract. Contractor will comply with all applicable federal, State of Florida, Miami-Dade County, and Town rules regulations, laws, and ordinance as applicable.

**C1.29 NOTICES**

Whenever either party desires to give written notice to the other relating to the Contract, such must be addressed to the party for whom it is intended at the place specified below; and the place for giving the notice will remain until it has been changed by written notice in compliance with the provisions of this Article. Notice will be deemed given on the date received or within 3 days of mailing, if mailed through the United States Postal Service. Notice will be deemed given on the date sent via e-mail or facsimile. Notice will be deemed given via courier/delivery service upon the initial delivery date by the courier/delivery service. For the present, the parties designate the following as the respective places for giving of notice:

For Town:

Mr. Edward Pidermann  
Town Manager  
Town of Miami Lakes  
6601 Main Street  
Miami Lakes, Florida 33014  
[pidermanne@miamilakes-fl.gov](mailto:pidermanne@miamilakes-fl.gov)

Lorenzo Cobiella  
Deputy Town Attorney  
Town of Miami Lakes  
6601 Main Street  
Miami Lakes, Florida 33014  
[cobiellal@miamilakes-fl.gov](mailto:cobiellal@miamilakes-fl.gov)

For Contractor:

**(To Be determined)**

Space intentionally left blank

During the Work the Contractor must maintain continuing communications with designated Town representative(s). The Contractor must keep the Town fully informed as to the progress of the Work under the Contract.

## **C2 INDEMNITY & INSURANCE**

### **C2.01 INDEMNIFICATION**

The Contractor must indemnify and hold harmless the Town, its officers, agents and employees from and against all liability, claims, damages, losses and expenses, including reasonable attorney's fees and costs at both trial and appellate levels arising out of or resulting from the performance of the Work under this Contract, caused by negligence, recklessness, intentional misconduct, or any act or omission of the Contractor or anyone directly or indirectly employed by Contractor or anyone for whose acts Contractor may be liable. The Contractor expressly understands and agrees that any insurance protection required by this Contract or otherwise provided by Contractor will in no way limit the responsibility to indemnify, keep and save harmless and defend the Town or its officers, employees, agents, and instrumentalities as herein provided.

The Contractor agrees and recognizes that the Town will not be held liable or responsible for any claims which may result from any actions or omissions of the Contractor in which the Town participated either through review or concurrence of the Contractor's actions. In reviewing, approving, or rejecting any submissions by the Contractor or other acts of the Contractor, the Town in no way assumes or shares any responsibility or liability of the Contractor or Subcontractor, under this Contract. The Contractor will defend the Town or provide for such defense at its own expense, at the Town's option.

This indemnification obligation will survive the expiration or termination of this Contract.

The Town has provided specific consideration for the indemnification of \$10.00 from the sums due to the Contractor under this Contract.

### **C2.02 CONTRACTOR'S RESPONSIBILITY FOR DAMAGES TO THE WORK**

Contractor accepts full responsibility for Work against all losses or damages of whatever nature sustained until acceptance by Town Manager or designee, and must promptly repair or replace, at no additional cost to the Town any Work, materials, equipment, or supplies damaged, lost, stolen, or destroyed from any cause whatsoever.

Contractor is full responsible for Work against all losses or damages of whatever nature sustained until acceptance by Town, and must promptly repair or replace, at no additional cost to the Town any Work, materials, equipment, or supplies damaged, lost, stolen, or destroyed from any cause whatsoever.

### **C2.03 DEFENSE OF CLAIMS**

Should any claim be made, or any legal action brought in any way relating to the Work under the Contract, the Contractor will diligently render to the Town all assistance which the Town may require of the Contractor.

### **C2.04 INSURANCE**

Without limiting any of the other obligations or liabilities of Contractor, the Contractor must secure and maintain throughout the duration of this Contract, insurance of such type and in such amounts necessary to protect its interest and the interest of the Town against hazards or risks of loss as specified below. The underwriter of such insurance must be qualified to do business in the State of Florida, be rated "B" as to management and "Class V" as to strength or better as rated by the latest edition of Best's Insurance Guide, published by A.M. Best Company, Oldwick, New Jersey, or its equivalent, the insurance carrier must have agents upon whom service of process may be made in the State of Florida. The insurance coverage will be primary insurance with respect to the Town, its officials, employees, agents, and volunteers. Any insurance maintained by the Town will be in excess of the Contractor's insurance and will not contribute to the Contractor's insurance. The insurance coverages must include a minimum of:

- a. *Worker's Compensation and Employer's Liability Insurance:*  
 Coverage to apply for all employees for statutory limits as required by the State of Florida's Statutory Workers' Compensation Law and all applicable Federal laws. The policy(ies) must include Employer's Liability with minimum limits of \$500,000 for each accident and a waiver of subrogation.
  
- b. *Comprehensive Business Automobile and Vehicle Liability Insurance:*  
 This insurance must be written in comprehensive form and must protect the Contractor and the Town against claims for injuries to members of the public and/or damages to property of others arising from the Contractor's use of motor vehicles or any other equipment and must cover operation with respect to onsite and offsite operations and insurance coverage must extend to any motor vehicles or other equipment irrespective of whether the same is owned, non-owned, or hired. The limit of liability must not be less than \$500,000 per occurrence, combined single limit for Bodily Injury Liability and Property Damage Liability. Coverage must be afforded on a form no more restrictive than the latest edition of the Business Automobile Liability Policy, without restrictive endorsement, as filed by the Insurance Services Office.
  
- c. *Commercial General Liability ("CGL"):*  
 This insurance must be written in comprehensive form and must protect the Contractor and the Town against claims arising from injuries to members of the public or damage to property of others arising out of any act or omission to act of the Contractor or any of its agents, employees, or subcontractors. The limit of liability must not be less than \$1,000,000 per occurrence, combined single limit for Bodily Injury Liability and Property Damage Liability. Coverage must be afforded on a primary and non-contributory basis and with a coverage form no more restrictive than the latest edition of the Commercial General Liability Policy, without restrictive endorsements, as filed by the Insurance Services Office, and must include: (1) Premises and/or Operations; (2) Independent contractors and Products and/or completed Operations; (3) Broad Form Property Damage, Personal Injury and a Contractual Liability Endorsement, including any hold harmless and/or indemnification agreement.
  - (1st) Products and/or Completed Operations for contracts with an Aggregate Limit of **One Million Dollars (\$1,000,000)** per project. Contractor must maintain in force until at least three years after completion of all Work required under the Contract, coverage for Products and Completed Operations, including Broad Form Property Damage.
  
  - (2nd) Personal and Advertising Injury with an aggregate limit of **One Million Dollars (\$1,000,000)**.
  
  - (3rd) CGL Required Endorsements:
    - a) Employees included as insured
    - b) Contingent Liability/Independent Contractors Coverage
    - c) Contractual Liability
    - d) Waiver of Subrogation
    - e) Premises and/or Operations
    - f) Explosion, Collapse and Underground Hazards (if not specifically covered under the policy)
    - g) Loading and Unloading
    - h) Mobile Equipment (Contractor's Equipment) whether owned, leased, borrowed, or rented by Contractor or employees of the Contractor.

d. *Certificate of Insurance*

Contractor must provide the Town Manager or designee with Certificates of Insurance for all required policies within fifteen (15) days of notification of a conditional award by the Town. The Certificates of Insurance must not only name the types of policy(ies) provided, but also must specifically cite this Contract and must state that such insurance is as required by this Contract. The Town reserves the right to require the Contractor to provide a certified copy of such policies, upon written request by the Town. Each policy certificate must be endorsed with a provision that not less than thirty (30) calendar days' written notice must be provided to the Town before any policy or coverage is cancelled, restricted, or a material change is made. Acceptance of the Certificate(s) is subject to approval of the Town Manager or designee.

e. *Additional Insured*

The Town is to be specifically included as an Additional Insured for the liability of the Town resulting from operations performed by or on behalf of Contractor in performance of this Contract. The Town must be named as additional insured under the CGL, business automobile insurance and umbrella policies. Town must be named as an additional insured under Contractor's insurance, including that applicable to the Town as an Additional Insured, must apply on a primary basis and any other insurance maintained by the Town will be in excess of and will not contribute to Contractor's insurance. Contractor's insurance must contain a severability of interest provision providing that, except with respect to the total limits of liability, the insurance must apply to each Insured or Additional Insured in the same manner as if separate policies had been issued to each.

All deductibles or self-insured retentions must be declared to and be approved by the Town Manager. The Contractor will be responsible for the payment of any deductible or self-insured retention in the event of any claim.

### **C3 PUBLIC RECORDS**

#### **C3.01 ACCESS, REVIEW AND RELEASE OF RECORDS**

Town will have the right to inspect and copy, at Town's expense, the books, records, and accounts of Contractor which relate in any way to the Contract. The Contractor agrees to maintain an accounting system that provides for accounting records that are supported with adequate documentation and adequate procedures for determining allowable costs.

f. *Public Records*

Bidder affirms, by virtue of bidding, that its Bid is a public record, and the public will have access to all documents and information pertaining to the bid and the solicitation, subject to the provisions of Chapter 119, Florida Statutes. Bidder acknowledges that the Town may provide public access to or provide copies of all documents subject to disclosure under applicable law. If the Project is funded by grants, either partially or fully, records will be made available to the granting agency in accordance with that agency's requirements, when necessary.

Bidder is responsible for claiming applicable exemptions to disclosure as provided by Chapter 119, Florida Statutes, in its Bid by identifying the materials to be protected and providing a reason for why such exclusion from public disclosure is necessary and legal.

g. *Retention and Transfer of Public Records*

Upon termination by the Town or final completion of the Contract the Contractor must, in accordance with Section 119.0701 of the Florida Statutes, transfer to the Town, at no cost, all public records in possession of the Contractor and destroy any duplicate public records that are exempt or confidential and exempt from public records disclosure requirements. All public record stored electronically must be provided in .pdf format

or another format acceptable to the Town. Any payments due the Contractor will not be made until the Town receives the public records. Failure to return such documents will result in the documents being subject Chapter 119 of the Florida Statutes

The Contractor must comply with the applicable provisions of Chapter 119, Florida Statutes, and Town will have the right to immediately terminate this Contract for the refusal by the Contractor to comply with Chapter 119, Florida Statutes. The Contractor must retain all other records associated with this Contract for a period of five (5) years from the date of termination.

**Should the Contractor have any questions related to the application of Chapter 119, Florida Statutes, to the Contractor’s duty to provide public records relating to this Contract, contact the Town’s custodian of public records at the Office of the Town Clerk 6601 Main Street, Miami Lakes, Florida 33014 either in writing to by telephone at (305) 364-6100 or [clerk@miamilakes-fl.gov](mailto:clerk@miamilakes-fl.gov).**

## **C4 CONTRACT MODIFICATION AND DISPUTE PROCESS**

### **C4.01 CHANGE ORDERS**

Without invalidating the Contract Documents, and without notice to any Surety, the Town reserves the right to make increases, decreases or other changes in the character or quantity of the Work under the Contract Documents as may be considered necessary or desirable to complete the Work in a manner satisfactory to the Town. The Town reserves the right to order changes which may result in additions to or reductions from the amount, type or value of the Work shown in the Contract, and which are within the general scope of the Contract Documents, and all such changes will be authorized only by a Change Order approved in advance and issued in accordance with provisions of the Town.

The Contractor is required to provide the Project Manager with a detailed Change Proposal Request (“CPR”) or Request for Change Order (“RCO”), utilizing the Town’s standard form, which must include requested revisions to the Contract, including but not limited to adjustments in this Contract Price and Contract Time. The Contractor is required to provide sufficient data in support of the cost proposal demonstrating its reasonableness. In furtherance of this obligation, the Town may require that the Contractor submit any or all of the following: a cost breakdown of material costs, labor costs, labor rates by trade, and Work classification and overhead rates in support of Contractor’s CPR/RCO. The Contractor’s CPR/RCO must include any schedule revisions and an explanation of the cost and schedule impact of the proposed change on the Project. If the Contractor fails to notify the Project Manager of any schedule changes associated with the proposed change, it will be deemed to be an acknowledgment by Contractor that the proposed work will not have any scheduling consequences.

Any changes to the Contract must be contained in a written Change order, using the Town’s Change Order Form, executed by both parties. However, under circumstances determined necessary by the Town, a Change Order may be issued unilaterally by Town.

In the event a satisfactory adjustment cannot be reached, and a Change Order has not been issued or time is of the essence, the Town reserves the right, at its sole option to direct the Contractor to proceed on a time and materials basis or make such arrangements as may be deemed necessary to complete the proposed additional Work.

Where the Town directs the Contractor to proceed on a time and materials basis, Contractor must maintain detailed records of all labor and material costs for review by the Town.

For all Change Orders the Contractor will be entitled to a combined profit and overhead rate for Change Orders that will not be in excess of ten percent (10%) inclusive of all direct/indirect costs including labor, material,

and equipment costs, unless the Procurement Manager determines that the complexity and risk of the Change Order work is such that an additional factor is appropriate.

The final amount to be paid to the Contractor for Change Order Work is subject to negotiation between the Town and the Contractor.

Failure by the Contractor to proceed with Change Order Work when so directed by the Town Manager or designee may result in the Contractor being found in default of the Contract.

Contractor must utilize the Town's standard requests for change orders and change order forms unless otherwise specifically approved by the Town's Procurement Manager. The Town's Forms are available on the Town's website.

#### C4.02 FORCE MAJEURE

Should any failure to perform on the part of Contractor be due to a condition of Force Majeure as that term is interpreted under Florida law, then, the Town may allow an extension of time reasonably commensurate with the cause of such failure to perform or cure.

If the Contractor is delayed in performing any obligation under the Contract Documents due to a force majeure condition, the Contractor must request a time extension from the Town within two (2) working days of said Force Majeure occurrence. Any time extension will be subject to mutual agreement and will not be cause for any claim by the Contractor for extra compensation unless additional services are required by the Town. A Force Majeure event **does not include** inclement weather except for significant weather events that adversely impact the critical path of the Project Schedule, if required, or completion of the work, and **does not include** the acts or omissions of Subcontractors or suppliers.

#### C4.03 EXTENSION OF TIME

Any reference in this Article to the Contractor will be deemed to include suppliers, and permitted Subcontractors, whether or not in privity of contract with the Contractor for the purpose of this Article.

If the Contractor is delayed at any time during the progress of the Work beyond the time frame or date provided for Final Completion by the neglect or failure of the Town or by a Force Majeure, then the Contract Time set forth in the Contract will be extended by the Town subject to the following conditions:

1. The cause of the delay arises after issuance of the NTP and could not have been anticipated by the Contractor by reasonable investigation before proceeding with the Work;
2. The Contractor demonstrates that the completion of the Work will be actually and necessarily delayed;
3. The effect of such cause cannot be avoided or mitigated by the exercise of all reasonable precautions, efforts, and measures whether before or after the occurrence of the cause of delay.

A delay meeting all the conditions of the above will be deemed an Excusable Delay.

The Town reserves the right to rescind or shorten any extension previously granted if subsequently, the Project Manager determines that any information provided by the Contractor in support of a request for an extension of time was erroneous; provided however, that such information or facts, if known, would have resulted in a denial of the request for an Excusable Delay. Notwithstanding the above, the Project Manager will not rescind or shorten any extension previously granted if the Contractor acted in reliance upon the granting of such extension and such extension was based on information which, although later found to have been erroneous, was submitted in good faith by the Contractor.

The request for an Excusable Delay must be made within five (5) calendar days after the time when the Contractor knows or should have known of any cause for a specific event, for which it may claim an extension of time and must provide any actual or potential basis for an extension of time, identifying such causes and describing, as fully as practicable at that time, the nature and expected duration of the delay and its effect on the completion of that part of the Work identified in the request. The Project Manager may require the

Contractor to furnish such additional information or documentation, as the Project Manager will reasonably deem necessary or helpful in considering the requested extension.

The Contractor will not be entitled to an extension of time unless the Contractor affirmatively demonstrates that it is entitled to such extension.

The Project Manager will endeavor to review and respond to the Contractor's request for Excusable Delays in a reasonable period of time; however, the Contractor is obligated to continue to perform the Work required regardless of whether the Project Manager has issued a decision or whether the Contractor agrees or disagrees with that decision.

With regard to an injunction, strike or interference of public origin which may delay the Project, the Contractor must promptly give the Project Manager a copy of the injunction or other orders and copies of the papers upon which the same was granted. The Town must be afforded the right to intervene and become a party to any suit or proceeding in which any such injunction has been obtained and move to dissolve the same or otherwise, as the Town may deem proper.

Where the Contractor is delayed for any period of time by two or more of the causes mentioned in Article C4.04, Excusable Delay, Non-Compensable, the Contractor will not be entitled to a separate extension for each one of the causes, only one period of extension will be granted for the delay.

Any extension of time granted by the Town will be processed through the Change Order provisions of the Contract.

The permitting of the Contractor to proceed with the Work subsequent to the date specified in the Contract (as such date may have been extended by a change order), the making of any payment to the Contractor, the issuance of any Change Order, will not waive the Town's rights under the Contract, including but not limited to the assessment of liquidated damages or declaring Contractor in default.

#### C4.04 EXCUSABLE DELAY, NON-COMPENSABLE

Excusable Delay is delay caused by either of the following: (i) circumstances that could not be foreseen and are beyond the reasonable control of Contractor, its subcontractors, or suppliers; or (ii) joint or concurrent action by Contractor, its subcontractors, suppliers or vendors and the Town. Then Contractor will be entitled only to a time extension and no compensation for the delay.

Contractor is entitled to a time extension of the Contract time for each day the Work is delayed due to Excusable Delay. Contractor must document its claim for any time extension as provided in Article C4.05.

Failure of Contractor to comply with Article C4.05, as to any particular event of delay will be deemed conclusively to constitute a waiver, abandonment or relinquishment of any and all claims resulting from that particular event of delay.

#### C4.05 CLAIMS

Contractor will only be entitled to submit a claim after submitting its request for additional compensation or time in accordance with Articles C4.03 and C4.04 of the Contract and the request(s) have been denied or the Contractor does not agree with the decision of the Town.

Any claim for a change in the Contract time for completion of any Work, the Contract Term, or Contract price must be made by written notice by Contractor to the Town representatives identified in Article C1.26 within the timeframe established in Article C4.04, effective with the commencement of the event giving rise to the claim stating the general nature and cause of the claim. Thereafter, within twenty (20) calendar days of the termination of the event giving rise to the claim, written notice of the extent of the claim with supporting information and documentation must be provided unless the Procurement Manager allows an additional period of time to ascertain more accurate data in support of the claim. The written notice must be accompanied by Contractor's written notarized statement that the adjustment(s) claimed is the entire

adjustment to which the Contractor has reason to believe it is entitled as a result of the occurrence of said event. All claims and disputes will be determined in accordance with the Contract. It is expressly and specifically agreed that any and all claims for changes to the Contract will be waived if not submitted in strict accordance with the requirements of this Article.

The Town may require the Contractor to submit its claim utilizing a specific format or forms to facilitate the Town's evaluation of the claim. The Town at its sole discretion may require that additional documentation or information be provided by the Contractor to assist in its review and evaluation of the claim.

The Contract time will be extended in an amount equal to time lost on critical Work items due to delays beyond the control of and through no fault or negligence of Contractor if a claim is made as provided in this Article. Such delays include, but are not to be limited to, acts or neglect by any separate contractor employed by Town, fires, floods, labor disputes beyond the control of the Contractor, epidemics, abnormal weather conditions (if applicable), or acts of God.

The Contractor will not be entitled to an increase in the Contract price or payment or compensation of any kind from the Town for direct, indirect, consequential, impact or other costs, expenses or damages, including but not limited to costs of acceleration or inefficiency, arising because of delay, disruption, interference or hindrance from any cause whatsoever, whether such delay, disruption, interference or hindrance be it reasonable or unreasonable, foreseeable or unforeseeable, avoidable or unavoidable. Contractor will only be entitled to an extension of the Contract Time for completion of the Work, as the sole and exclusive remedy for such resulting excusable delay.

The Contractor agrees to make no claim for damages for delay of any kind in the performance of the Contract Documents whether occasioned by any act or omission of the Town or any of its representatives and the Contractor agrees that any such claim will be compensated solely by an extension of time to complete performance of the Work due to an Excusable Delay as defined in Articles C4.03, and Article C4.04. The Contractor alone specifically assumes the risk of such delays, including, without limitation: delays in processing or approving any submittals to the Town or by the Town, or the failure to render determinations, approvals, replies, inspections, in a timely manner. Contractor will not receive monetary compensation for Town delay(s).

Failure of Contractor to comply with this Article as to any particular event of claim will be deemed conclusively to constitute a waiver of any and all claims resulting from that particular event.

#### **C4.06 CONTINUING THE WORK**

Contractor must continue to perform all Work under the Contract Documents during all disputes or disagreements with Town, including disputes or disagreements concerning a request for a Change Order and no Work must not be delayed or postponed pending resolution of any disputes or disagreements.

#### **C4.07 FRAUD AND MISREPRESENTATION**

The Town may terminate this Contract or any other contracts with the Town with any person, individual, corporation, entity, or affiliate that attempts to meet its contractual obligations with the Town through fraud, misrepresentation, or material misstatement. Such person, individual, corporation, entity, or affiliate will be responsible for all direct or indirect costs associated with termination or cancellation.

#### **C4.08 STOP WORK ORDER**

The Town may, at any time, by written order to the Contractor, require the Contractor to stop all, or any part, of the Work for a period of up to ninety (90) days (or any lesser period), commencing no sooner than the date the order is delivered to the Contractor, and for any further period to which the parties may agree. Any such order will be specifically identified as a "Stop Work Order" issued pursuant to this paragraph. Within the period of ninety (90) days (or the lesser period specified) after a Stop Work Order is delivered to the Contractor, or within any extension to which the parties have agreed the Town will either:

1. Cancel the Stop Work Order; or
2. Terminate the Work covered by such order as provided in Article C5.03, Termination for Convenience.

If a Stop Work Order issued under this Article is canceled or the period of the order or any extension thereof expires, the Contractor must resume the Work without compensation to the Contractor for such suspension other than extending the time to complete any Work under the Contract or extending the Contract Term to the extent that, in the opinion of the Project Manager, the Contractor may have been delayed by such suspension. In the event the Project Manger determines that the suspension of Work was necessary due to Contractor's defective or incorrect Work, unsafe Work conditions caused by the Contractor, or any other reason caused by Contractor's fault or omission, the Contractor will not be entitled to an extension of time or Contract Term or (Time) as a result of the issuance of a Stop Work Order.

Suspension of the Work caused by a threatened or actual storm event, regardless of whether the Town has directed such suspension, will entitle the Contractor to additional Contract time as non-compensable, Excusable Delay, and will not give rise to a claim for compensable delay.

#### **C4.09 MATERIALITY AND WAIVER OF BREACH**

Town and Contractor agree that each requirement, duty, and obligation set forth in the Contract Documents is substantial and important to the formation of the Contract Documents and, therefore, is a material term hereof. The Town's failure to enforce any provision of the Contract Documents will not be deemed a waiver of such provision or modification of the Contract Documents. A waiver of any breach of a provision of the Contract Documents will not be deemed a waiver of any subsequent breach and will not be construed to be a modification of the terms of the Contract Documents.

#### **C4.10 TIME IN WHICH TO BRING ACTION AGAINST THE TOWN**

In the event the Contractor may be deemed to have a cause of action against the Town, no action will lie or be maintained by the Contractor against the Town upon any claim arising out of or based upon the Contract Documents by reason of any act or omission or requirement of the Town or its agents, unless such action is commenced within six (6) months after the date of issuance of a final payment under the Contract, or if the Contract is terminated under the provisions of the Contract, unless such action is commenced within six (6) months after the date of such termination by the Town.

#### **C4.11 CONTRACT EXTENSION**

The Town reserves the right to extend the Contract for up to ninety (90) calendar days beyond the original Contract period, inclusive of any Options to Renew exercised by the Town. In such event, the Town will notify the Contractor in writing of such extensions.

### **C5 EARLY TERMINATION & DEFAULT**

#### **C5.01 SET-OFFS, WITHHOLDING, AND DEDUCTIONS**

The Town may set-off, deduct or withhold from any payment due the Contractor, such sums as may be specifically allowed in the Contract or by applicable law including, without limitation, the following:

1. Any amount of any claim by a third party;
2. Any Liquidated Damages, and/or;
3. Any unpaid legally enforceable debt owed by the Contractor to the Town.

The Town will notify the Contractor in writing of any such withholdings.

Any withholding, which is ultimately held to have been wrongful, will be paid to the Contractor in accordance with the Local Government Prompt Payment Act

## C5.02 CONTRACTOR DEFAULT

An event of default means a breach of the Contract by the Contractor. Without limiting the generality of the foregoing and in addition to those instances referred to herein as a breach, an Event of Default, includes but is not limited to, the following:

1. The Contractor has not performed the Work in a timely manner;
2. The Contractor has refused or failed to supply properly skilled staff or provided sufficient quantities of staff to perform the Work;
3. The Contractor has failed to make prompt payment to Subcontractors or suppliers for any services, materials, or supplies provided to Contractor;
4. The Contractor has become insolvent or has assigned the proceeds received for the benefit of the Contractor's creditors, or the Contractor has taken advantage of any insolvency statute or debtor/creditor law or if the Contractor's affairs have been put in the hands of a receiver;
5. The Contractor has failed to obtain the approval of the Town where required by the Contract Documents;
6. The Contractor has failed in the representation of any warranties stated herein;
7. When, in the opinion of the Town, reasonable grounds for uncertainty exist with respect to the Contractor's ability to perform the Work.

### *h. Notice of Default – Opportunity to Cure*

Where an Event of Default ("Default") occurs under the Contract, the Town may at its sole discretion notify the Contractor, specifying the basis for such Default, and advising the Contractor that such Default must be cured within a time frame specified by the Town; or the Contract with the Town may be terminated. The Town is under no obligation to issue such notification. The Town may grant an extension to the cure period if the Town deems it appropriate and in the best interest of the Town, without waiver of any of the Town's rights hereunder. The Town, at its sole discretion, may have a default corrected by its own forces or another contractor and any such costs incurred will be deducted from any sums due the Contractor under any contract with the Town.

The Town Manager or designee may also suspend any payment or part thereof or order a Work stoppage until such time as the issue(s) concerning compliance are resolved.

### *i. Termination for Default*

Where a Default is not cured within the time specified to cure the Default, the Town Manager in addition to all remedies available by law, may immediately, upon written notice to Contractor, terminate this Contract. Contractor understands and agrees that termination of this Contract under this Article will not release Contractor from any obligation accruing prior to the effective date of termination.

In the event of termination by the Town Manager or designee, the Town Manager or designee may immediately take possession of all applicable documentation and data, material, equipment, and supplies to which it is entitled to under the Contract or by law.

Where the Town erroneously terminates the Contract for default, the terminations will be converted to a Termination for Convenience, and the Contractor will have no further recourse of any nature for wrongful termination.

## C5.03 TERMINATION FOR CONVENIENCE

In addition to cancellation or termination as otherwise provided for in the Contract, the Town may at any time, in its sole discretion, with or without cause, terminate the Contract by written notice to the Contractor. Such Written Notice will state the date upon which Contractor must cease all Work under the Contract, and if applicable vacate the Project(s) site(s).

Upon receipt of such notice, unless otherwise directed by the Town, the Contractor must Stop all Work on the date specified in the notice (“the Effective Date”);

1. Take such action as may be necessary for the protection and preservation of the Town’s materials and property;
2. Cancel all cancelable orders for materials and equipment;
3. Remove all materials, supplies or equipment that may be used by the Contractor on other work;
4. Assign to the Town and deliver to the Town, at a site(s) specified by the Town, any non-cancelable orders for materials and equipment that can not otherwise be used by the Contractor on other work;
5. Take no action that will increase the amounts payable by the Town under the Contract Documents; and take reasonable measures to mitigate the Town’s liability under the Contract Documents; and
6. All documents, including electronic documents, related to Work authorized under the Contract, whether finished or not, must be turned over to the Town. Failure to timely deliver the documentation will be cause to withhold any payments due without recourse by Contractor until all documentation is delivered to the Town.

In the event that the Town exercises its right to terminate the Contract pursuant to the Contract Documents, the Town will pay the Contractor for the actual cost, or the fair and reasonable value, as substantiated by invoice documentation, of any non-cancelable material(s) and equipment that cannot be used elsewhere by the Contractor in the performance of its work.

In no event, will any payments under this Paragraph exceed the maximum cost set forth in the Contract and the amount due hereunder may be offset by payments made to the Contractor or any claims made against the Contractor. Contractor will not be entitled to lost profits, overhead or consequential damages as a result of a Termination for Convenience.

#### **C5.04 REMEDIES AVAILABLE TO THE TOWN**

The Town may avail itself of each and every remedy stated in the Contract Documents or existing at law or in equity. The exercise or the beginning of the exercise of one remedy will not be deemed a waiver of the right to exercise, at the same time or thereafter, of any other remedy.

#### **C5.05 FUNDS AVAILABILITY**

Funding for this Contract is contingent on the availability of funds and the Contract is subject to amendment or termination due to lack of funds, reduction of funds and/or change in regulations, upon thirty (30) days’ notice.

### **C6 PAYMENT PROCESS**

#### **C6.01 COMPENSATION**

Contractor can submit an invoice for payment for Work performed once per month for work completed and acceptance by the Project Manager. Contractor may not invoice more than once per month.

Contractor must use the Town’s Contractor Payment Application (“Invoice”) for all payment requests. Failure to use the Invoice form and fully complete the required information will delay payment. Payments will not be made based on statements of accounts.

The Invoice Form is available on the Town’s website at [Town of Miami Lakes - Growing Beautifully - Invoice \(miamilakes-fl.gov\)](https://www.miamilakes-fl.gov).

The Town will take action to pay, reject or make partial payment on an Invoice in accordance with the Florida Local Government Prompt Payment Act. No payments will be due or payable for Work not performed or materials not furnished or where the Work has not been accepted by the Town. If there is a dispute with regard to an invoice, the Town will pay the amount not in dispute and reject the remainder that is in dispute.

Contractor is responsible for paying its Subcontractors and suppliers in accordance with the Florida Local Government Prompt Payment Act.

The Contractor will be compensated based on actual Work performed at the prices specified in the Contract.

The acceptance of final payment for a Project constitutes a waiver of all claims by Contractor related to that Project, except those previously made in strict accordance with the provisions of the Contract and identified by Contractor as unsettled at the time of the application for payment.

#### C6.02 ESTIMATED QUANTITIES

The stated quantities do not reflect the actual quantities to be ordered and the Town has not established any minimum quantities and no guarantee is expressed or implied as to the total quantity of Work to be issued to a Contractor. The Town reserves the right, at its sole discretion, to make adjustment to the number and/or location of the Bid items. The failure of the Town to order any minimum quantities does not form any basis for a claim by the Contractor for lost work or profits.

#### C6.03 LINE-ITEM PRICING

Line-item pricing must include all costs, both direct and indirect to perform the Work except for those costs specifically identified as reimbursable costs as stated in Article C6.06. This includes any incidental costs associated with the Work not specifically stated, i.e., the installation of drainage may require backfill and patching, whether permanent or temporary.

The Bid Form contains line-item prices, and the Bidder is required to Bid on all line items. Where a Bidder fails to provide line-item prices for all line items the Bid will be rejected as non-responsive.

#### C6.04 LINE-ITEM QUANTITIES

The estimated quantities will be used solely for bid comparison purposes for the Bidder to determine the lowest responsive and responsible. No guarantee is expressed or implied as to the total quantity of Work to be issued to a Contractor.

#### C6.05 ADDITIONAL LINE-ITEM PRICING

The Town reserves the right to request price quotes for additional items not contained in the initial award. Should the Town add any additional line items the Town will do so through the Change Order process.

#### C6.06 REIMBURSIBLE EXPENSES

Certain Project expenses may or will not be known at the time of award of a Project. The Town will reimburse the Contractor for such costs, which includes:

1. Permits
2. Police Officer costs when not provided by the Town
3. WASD fees
4. DERM fees

Where a permit or the Town requires the Contractor to use a police officer(s) during the performance of the Work the Town will make every effort to furnish police officers at no cost to the Contractor. Where the Town is not able to provide the required police officers the Town will reimburse the Contractor based on the actual cost to the Contractor and the cost is not include in the unit price per item. To be reimbursed the Contractor must submit a copy of documentation substantiating both the cost as well as proof of payment.

Contractor will only be reimbursed for the actual direct cost, without any mark-up.

## **C7 AMERICAN RESCUE PLAN REQUIRED CONTRACTUAL PROVISIONS**

### **C7.01 EQUAL OPPORTUNITY EMPLOYMENT**

During the performance of this contract, the Contractor agrees as follows:

1. The Contractor will not discriminate against any employee or applicant for employment because of race, color, religion, sex, sexual orientation, gender identity, or national origin. The Contractor will take affirmative action to ensure that applicants are employed, and that employees are treated during employment without regard to their race, color, religion, sex, sexual orientation, gender identity, or national origin. Such action shall include, but not be limited to the following:
  - a. Employment, upgrading, demotion, or transfer; recruitment or recruitment advertising, layoff, or termination; rates or pay or other forms of compensation; and selection for training, including apprenticeship. The Contractor agrees to post in conspicuous places, available to employees and applicants for employment, notices to be provided setting forth the provisions of this nondiscrimination clause.
2. The Contractor will, in all solicitations or advertisements for employees placed by or on behalf of the Contractor, state that all qualified applicants will receive considerations for employment without regard to race, color, religion, sex, sexual orientation, gender identity, or national origin.
3. The Contractor will not discharge or in any other manner discriminate against any employee or applicant for employment because such employee or applicant has inquired about, discussed, or disclosed the compensation of the employee or applicant or another employee or applicant. This provision shall not apply to instances in which an employee who has access to the compensation information of other employees or applicants as a part of such employee's essential job functions discloses the compensation of such other employees or applicants to individuals who do not otherwise have access to such information, unless such disclosure is in response to a formal complaint or charge, in furtherance of an investigation, proceeding, hearing, or action, including an investigation conducted by the employer, or is consistent with the contractor's legal duty to furnish information.
4. The Contractor will send to each labor union or representative of workers with which he has a collective bargaining agreement or other contract or understanding, a notice to be provided advising the said labor union or workers' representatives of the contractor's commitments under this section and shall post copies of the notice in conspicuous places available to employees and applicants for employment.
5. The Contractor will comply with all provisions of Executive Order 11246 of September 24, 1965, and of the rules, regulations, and relevant orders of the Secretary of Labor.
6. The Contractor will furnish all information and reports required by Executive Order 11246 of September 24, 1965, and by rules, regulations, and orders of the Secretary of Labor, or pursuant thereto, and will permit access to his books, records, and accounts by the administering agency and the Secretary of Labor for purposes of investigation to ascertain compliance with such rules, regulations, and orders.
7. In the event of the contractor's noncompliance with the nondiscrimination clauses of this Agreement or with any of the said rules, regulations, or orders, this Agreement may be canceled, terminated, or suspended in whole or in part and the contractor may be declared ineligible for further Government contracts or federally assisted construction contracts in accordance with procedures authorized in Executive Order 11246 of September 24, 1965, and such other sanctions may be imposed and remedies invoked as provided in Executive Order 11246 of September 24, 1965, or by rule, regulation, or order of the Secretary of Labor, or as otherwise provided by law.

8. The Contractor will include the portion of the sentence immediately preceding paragraph 1(a)(ii) of this section and the provisions of subparagraphs (1) through (8) in every subcontract or purchase order unless exempted by rules, regulations, or orders of the Secretary of Labor issued pursuant to section 204 of Executive Order 11246 of September 24, 1965, so that such provisions will be binding upon each subcontractor or vendor. The contractor will take such action with respect to any subcontract or purchase order as the administering agency may direct as a means of enforcing such provisions, including sanctions for noncompliance. Provided, however, that in the event a contractor becomes involved in, or is threatened with, litigation with a subcontractor or vendor as a result of such direction by the administering agency, the contractor may request the United States to enter into such litigation to protect the interests of the United States.

#### C7.02 COPELAND ANTI-KICKBACK ACT

The Contractor shall comply with 18 U.S.C. § 874, 40 U.S.C. § 3145, and the requirements of 29 CFR pt. 3 as may be applicable, which are incorporated by reference into this contract.

#### C7.03 CONTRACT WORK HOURS AND SAFETY STANDARDS

Where applicable, if the Contract is in excess of \$100,000 and involves the employment of mechanics or laborers, the Town must comply with 40 U.S.C. 3702 and 3704, as supplemented by Department of Labor regulations (29 CFR Part 5). Under 40 U.S.C. 3702 of the Act, each Town must be required to compute the wages of every mechanic and laborer on the basis of a standard work week of 40 hours. Work in excess of the standard work week is permissible provided that the worker is compensated at a rate of not less than one and a half times the basic rate of pay for all hours worked in excess of 40 hours in the work week. The requirements of 40 U.S.C. 3704 are applicable to construction work and provide that no laborer or mechanic must be required to work in surroundings or under working conditions which are unsanitary, hazardous, or dangerous. These requirements do not apply to the purchases of supplies or materials or articles ordinarily available on the open market, or contracts for transportation or transmission of intelligence.

#### C7.04 CLEAN AIR ACT AND THE FEDERAL WATER POLLUTION CONTROL ACT

Contractor agrees to comply with all applicable standards, orders or regulations issued pursuant to the Clean Air Act (42 U.S.C. 7401-7671q) and the Federal Water Pollution Control Act as amended (33 U.S.C. 1251-1387) and will report violations to FEMA and the Regional Office of the Environmental Protection Agency (EPA).

#### C7.05 SUSPENSION AND DEBARMENT

- i. This Contract is a covered transaction for purposes of 2 C.F.R. Part 180 and 2 C.F.R. Part 3000. As such, the Contractor is required to verify that neither the Contractor, its principals (defined at 2 C.F.R. § 180.995) or its affiliates (defined at 2 C.F.R. § 180.905) are excluded (defined at 2 C.F.R. § 180.940) or disqualified (define at 2 C.F.R. § 180.935).
- ii. The Contractor must comply with 2 C.F.R. Part 180, subpart C and 2 C.F.R. Part 3000, subpart C, and must include a requirement to comply with these regulations in any lower tier covered transaction it enters.
- iii. This certification is a material representation of fact relied upon by the Division. If it is later determined that the Contractor did not comply with 2 C.F.R. Part 180, subpart C and 2 C.F.R. Part 3000, subpart C, in addition to remedies available to the Division, the Federal Government may pursue available remedies, including but not limited to suspension and/or debarment.
- iv. The bidder or proposer agrees to comply with the requirements of 2 CFR pt. 180, subpart C and 2 CFR pt. 3000 subpart C while this offer is valid and throughout the period of any contract that may arise from this offer. The bidder or proposer further agrees to include a provision requiring such compliance in its lower tier covered transactions.

## **C7.06 BYRD ANTI-LOBBYING AMENDMENT**

Byrd Anti-Lobbying Amendment, 31 USC. § 1352 (as amended). Contractors who apply or bid for an award of \$100,000 or more shall file the required certification. Each tier certifies to the tier above that it will not and has not used Federal appropriated funds to pay any person or organization for influencing or attempting to influence an officer or employee of any agency, a member of Congress, officer or employee of Congress, or an employee of a member of Congress in connection with obtaining any Federal contract, grant, or any other award covered by 31 U.S.C. § 1352. Each tier shall also disclose any lobbying with non-Federal funds that takes place in connection with obtaining any Federal award. Such disclosures are forwarded from tier to tier up to the Town.

**END OF SECTION**

## **SECTION D. SPECIAL TERMS & CONDITIONS**

### **D1 SCOPE OF WORK**

The Work consists of furnishing all labor, materials, machinery, tools, means of transportation, supplies, equipment, and services necessary for drainage and road improvements including drainage system installation, milling, and resurfacing, thermoplastic pavement markings, and site restoration [including landscaping swale, concrete curb and gutter, driveways (asphalt, paver, or concrete), mailbox, street signs, etc.] as detailed in the plans and specifications attached hereto as Exhibit A.

### **D2 CONTRACT TERM**

The Contract will become effective on the date it is executed by both parties and shall remain in effect until the expiration of the Warranty period(s). The Contractor shall obtain Substantial Completion of the Work within three hundred (300) Days of the Notice to Proceed being issued by the Town. Contractor must obtain Final Completion within thirty (30) Days after obtaining Substantial Completion.

### **D3 COMPENSATION**

Contractor shall provide the Town with an invoice within thirty (30) days of the date services were rendered. At a minimum, the invoice must contain the following information:

- Name and address of the Contractor
- Contract number
- Date of invoice
- Invoice numbers (Invoice numbers cannot be repeated)
- Work performed, including a detailed list of area where Work was performed, the products and applicable quantities applied per area of Work.
- Monthly or quarterly price(s) of Work performed
- Total value of the invoice

Failure to include the above information will delay payment. Payments will not be made based on statements of accounts.

The Town will take action to pay, reject or make partial payment on an invoice in accordance with the Florida Local Government Prompt Payment Act. No payments shall be due or payable for Services not performed or materials not furnished or where the Service has not been accepted by the Town. If there is a dispute with regard to an invoice, the Town will pay the amount not in dispute and reject the remainder that is in dispute.

The Contractor shall be compensated at the line-item prices specified in the Bid Form of the Contract.

### **D4 SPECIFICATIONS**

Florida Department of Transportation (FDOT) and Miami-Dade Transportation and Public Works Department

(MDTPW) specifications apply in the performance of the Work and all applicable specifications are hereby incorporated by reference. The Town may, at its sole discretion, make changes to the FDOT and MDTPW specification and the Contractor will be advised of any such changes.

**D5 LIQUIDATED DAMAGES**

The Town may establish liquidated damages on the Noticed to Proceed.

The Contractor is obligated and guarantees to obtain Substantial and Final Completions of the Project within the timeframes established in the Contract or any approved extension of time the Contractor may be granted by the Town. In the event of a delay in completion beyond the date established in the Contract, the Contractor must pay to the Town for each and every calendar day of unexcused delay, the sum of one thousand dollars (\$1000), which is hereby agreed upon not as a penalty but as liquidated damages. The Contractor will be notified of any exceptions. The total amount of liquidated damages will not exceed the value of the Contract.

The Town has the right to deduct liquidated damages assessments from any payment due or which may thereafter become due to the Contractor under any contract the Contractor has with the Town. In case the amount available under contracts the Contractor has with the Town is less than the number of liquidated damages due the Town, the Contractor must pay the difference upon demand by the Town. Should the Contractor fail to compensate the Town for any liquidated damages, the Town will consider this as a form of indebtedness and may deny any future Work under the Contract or any other Town contract until such indebtedness is paid in full to the Town.

The Town will notify the Contractor in writing that it is incurring liquidated damages.

**D6 WARRANTY**

Contractor warrants to the Town that all materials and equipment furnished under the Contract will be new unless otherwise specified and that all of the Work will be of good quality, free from faults and defects and in conformance with the Contract Documents. All Work not conforming to these requirements, including substitutions not properly approved and authorized, may be considered defective. If required by the Project Manager, the Contractor must furnish satisfactory evidence as to the kind and quality of materials and equipment. This warranty is not limited by any other provisions within the Contract Documents.

All Work must have a one (1) year warranty on labor from the date of acceptance of the Work by the Town. Contractor must provide a minimum written warranty of one (1) year on all equipment, parts, or material unless the manufacturer provides a longer warranty. Where the manufacturer of the equipment, parts, or material provides a warranty greater than one (1) year, or the time frame stipulated, then the manufacturer’s warranty term will take precedence. Contractor will be required to provide the Project Manager with a copy of the manufacturer’s warranty prior to the Town issuing final payment. Manufacturer’s warranties will become effective upon Final Completion of the Project.

All material and equipment furnished must be fully guaranteed by the Contractor against factory defects and workmanship. At no expense to the Town, the Contractor will correct any and all apparent and latent defects that may occur within the manufacturer’s standard warranty. The Contract Documents may supersede the manufacturer’s standard warranty. Manufacturer’s warranties will become effective upon Final Completion of the Project.

Should the Contractor fail to perform any required warranty work the Town, at its sole discretion, may have the work performed by others, and deduct such costs from any monies due the Contractor from the Town. Where such funds are not available, the Town will bill the Contractor and Contractor will reimburse the Town within thirty (30) calendar days. The Town may take any necessary and appropriate action provided under this Contract or with law to collect such payment due the Town.

**D7 SUBSTANTIAL COMPLETION, PUNCHLIST & FINAL COMPLETION**

The Work will be substantially complete when the Project Manager, in the reasonable exercise of his/her discretion determines that the Work is complete and there are no material or substantial variations from the Contract and the Work is fit for its intended purpose. Upon Substantial Completion, the Project Manager and the Contractor will sign

the Substantial Completion Inspection Form. The signing of this form does not relieve the Contractor from its obligation to complete the Project.

During this inspection, the Project Substantial Completion Inspection Form will be completed as necessary. Any remaining Construction Work must be identified on this form, and it will be known as Punch List Work. The Punch List must be signed by the Project Manager and the Contractor confirming that the Punch List contains the item(s) necessary to complete the Work. The failure or refusal of the Contractor to sign the Project Substantial Completion Inspection Form or Punch List will not relieve the Contractor from complying with the findings of the Project Substantial Completion Inspection and completing the Project to the satisfaction of the Town.

The Project Manager or Consultant, and the Contractor will agree on the time reasonably required to complete all remaining Work included in the Punch List.

Upon Substantial Completion and the receipt and acceptance of any required documentation, including warranty documents, the Project Manager will determine that a Project has achieved Final Completion and authorize final payment.

The acceptance of final payment will constitute a waiver of all claims by Contractor, except those previously made in strict accordance with the provisions of the Contract and identified by Contractor as unsettled at the time of the application for final payment.

#### **D8 ACCEPTANCE AND FINAL PAYMENT**

Upon receipt of written notice from Contractor that the Work is ready for final inspection and acceptance, Project Manager will, within ten (10) calendar days, make an inspection thereof. If Project Manager find the Work acceptable, the requisite documents have been submitted and the requirements of the Contract fully satisfied, and all conditions of the permits and regulatory agencies have been met, a Final Certificate for Payment will be issued by Project Manager, stating that the requirements of the Contract have been performed and the Work is ready for acceptance under the terms and conditions thereof.

Before issuance of the Final Certificate for Payment, Contractor must deliver to the Project Manager a final release of all liens arising out of the Contract, receipts in full in lieu thereof; an affidavit certifying that all suppliers and subcontractors have been paid in full and that all other indebtedness connected with the Work has been paid, and a consent of the surety to final payment; the final corrected as-built drawings; operations and maintenance data, and the final bill of materials, if required, and payment application. Contractor must deliver the written Contractor's and all Manufacturer's warranties prior to issuance of the final invoice.

If, after the Work has been substantially completed, full completion thereof is materially delayed through no fault of Contractor, and Project Manager so certifies, Town will, upon such certification of Consultant, and without terminating the Contract, make payment of the balance due for that portion of the Work fully completed and accepted. Such payment will be made under the terms and conditions governing final payment, except that it will not constitute a waiver of claims.

The acceptance of final payment will constitute a waiver of all claims by Contractor, except those previously made in strict accordance with the provisions of the Contract and identified by Contractor as unsettled at the time of the application for final payment.

#### **D9 E-VERIFY**

Contractor shall utilize the U.S. Department of Homeland Security's E-Verify System to verify the employment eligibility of all new employees hired by the Contractor during the Term of the Contract and must expressly require any Subcontractors performing Work or providing services pursuant to the Contract to likewise utilize the U.S. Department of Homeland Security's E-Verify System to verify the employment eligibility of all new employees hired by the Subcontractor.

## **D10 NPDES REQUIREMENTS**

Contractor must comply with the State of Florida rules and regulations for the National Pollutant Discharge Elimination System (NPDES) including but not limited to all permitting, Notices of Intent, and the Storm Water Pollution Prevention Plan (SWPPP). All costs for NPDES and SWPPP must be included in the Bid price. For further information on compliance requirements for NPDES and SWPPP visit the State of Florida website at <http://www.dep.state.fl.us/water/stormwater/npdes/>. Contractor is responsible for obtaining, completing, and paying for any required NPDES application or permits that may be required.

## **D11 STAGING SITE**

The Contractor is solely responsible for making all arrangements for daily staging site(s) that may be necessary for the performance of the Service. The Town shall not be responsible for any security or any loss, damage or theft to the Contractor's vehicles, equipment, or materials. The Contractor shall also be responsible for restoring the site to its pre-existing condition prior to the Contractor's use of the site should the Contractor cause any damage to the area.

## **D12 PROJECT HOUSEKEEPING**

The Contractor is solely responsible for the following:

- Providing temporary sanitary facilities
- Providing Dust Control Measures during construction, including soil tracking devices (if necessary)
- Provide Debris & Pollution Control – Maintaining project site clean and orderly, providing containers for the disposal of debris, schedule periodic collection and disposal of debris.
- Staging areas must have sediment and erosion control measures installed prior to use.
- All vegetation, debris, concrete, or other unsuitable material shall be disposed of offsite, in an area provided by the contractor.
- Contractor to designate an area within the project limits for concrete truck washout activities. This area shall contain erosion control devices that prevent contact between washout materials and Stormwater and/or surface waters.
- All trenches/excavation shall be adequately covered at the end of the workday.

**END OF SECTION**

## **SECTION E. FORMS**

**BID FORM**

This Bid is submitted on behalf of Master Road Finishers (hereinafter "Bidder") located at  
(Name of Bidder)

18400 SW 202 St Miami FL 33187, submitted on July 11<sup>th</sup>, 24  
(Address) (Date)

to furnish all Work as stated in the ITB and Contract Documents for ITB No. 2024-19 for

Loch Lomond North Drainage Improvement Project  
(Solicitation Title)

To: Town of Miami Lakes, Florida  
Attn: Town Clerk  
Government Center  
6601 Main Street  
Miami Lakes, Florida 33014

This Bid Form is submitted as part of the Bidder's Bid submittal ("Submittal") in response to the above stated ITB issued by the Town of Miami Lakes.

Bidder has carefully examined all the documents contained in the ITB and understands all instructions, requirements, specifications, drawings/plans, terms, and conditions, and hereby offers and proposes to furnish the products or services described herein at the prices, fees or rates quoted in the Submittal, and in accordance with the requirements, specifications, drawings/plans, terms and conditions, and any other requirements of the Contract Documents.

Bidder has the necessary experience, knowledge, abilities, skills, and resources to satisfactorily perform the requirements under this ITB and attests to meeting the minimum qualifications stated therein.

All statements, information and representations prepared and submitted in response to the ITB are current, complete, true, and accurate. Bidder acknowledges that the Town will rely on such statements, information, and representations in selecting a Bidder, and hereby grants the Town permission to contact any persons or entities identified in the ITB to independently verify the information provided herein.

No attempt has or will be made by the Bidder to induce any other person or firm to not submit a response to this ITB and no personnel currently employed by the Town participated, directly or indirectly, in any activities related to the preparation of the Submittal. Bidder has had no contact with Town personnel regarding the ITB. If contact has occurred, except as permitted under the Cone of Silence, state and include a statement identifying in detail the nature and extent of such contacts and personnel involved.

The pricing, rates or fees proposed by the Bidder have been arrived at independently, without consultation, communication, or agreement, for the purpose of restriction of competition, as to any other Bidder or competitor; and unless otherwise required by law, the prices quoted have not been disclosed by the Bidder prior to submission of the Submittal, either directly or indirectly, to any other Bidder or competitor.

Bidder is not currently disqualified, de-listed or debarred from doing business with any public entity, including federal, state, county, or local public entities. If yes, Bidder must provide a detailed explanation of such disqualification, de-listing, or debarment, including the reasons and timeframe.

The Bidder agrees, if this Bid is accepted, to timely execute a contract with the Town, pursuant to the terms and conditions of the Contract Documents and to furnish the documents, equipment, machinery, tools, apparatus, means of transportation, and all labor necessary to complete the Work.

The individual signing the Bid Form represents by signing, that he/she is duly authorized to sign on behalf of the Bidder and that all information and documents submitted in response to the ITB are to the best of his/her knowledge are true, accurate, and complete as of the submittal date.

### BID PRICE

Bidder must complete and submit with its bid an electronic version of the MS Excel Bid Form-PS to be responsive. A printed copy of the MS Excel Bid Form may be included as part of the Bid Submittal by the Bidder. **Do not** convert the MS Excel Bid Form to a .pdf form.

Bidder's **TOTAL BID AMOUNT** includes the total cost for the Work specified in this solicitation, consisting of furnishing all materials, labor, equipment, supervision, mobilization, overhead & profit required, in accordance with the Contract Documents.

**Total Bid Amount (written out):**

One Million Three Hundred Fifty-Four Thousand  
Two Hundred ninety Dollars and Forty Cents

Total Bid Amount: \$ 1,354,290.40

Firm's Name: Master Road Finishers Corp.

SSN or Federal ID No.: 47-2674893 Telephone No.: 305-456-2317

E-Mail Address: claro@masterroad Facsimile No.: \_\_\_\_\_  
finishers.com

Town/State/Zip: Miami FL 33187

Printed Name/Title: Oswaldo Claro Signature: 

**LOCH LOMOND NORTH DRAINAGE IMPROVEMENTS**

**Bid Form**

<b>PAY ITEM NO.</b>	<b>DESCRIPTION</b>	<b>UNIT OF MEASUREMENT</b>	<b>QUANTITY</b>	<b>UNIT PRICE</b>	<b>TOTAL</b>
1	Mobilization	LS	1	\$ 10,000.00	\$ 10,000.00
2	Maintenance of Traffic	LS	1	\$ 15,000.00	\$ 15,000.00
3	Site Preparation and Restoration	LS	1	\$ 10,000.00	\$ 10,000.00
4	Floating Turbidity Barrier	LS	1	\$ 4,800.00	\$ 4,800.00
5	Silt Fence	LF	8,300	\$ 1.85	\$ 15,355.00
6	Drop Inlet Sediment Barrier	EA	12	\$ 300.00	\$ 3,600.00
7	Milling existing pavement (100")	SY	7,500	\$ 5.00	\$ 37,500.00
8	Asphalt Overlay, Type SP-9.5 (10")	TN	645	\$ 184.50	\$ 118,002.50
9	Concrete Sidewalk, Driveway, and Apron up to 6" thick	SY	450	\$ 76.50	\$ 34,425.00
10	Concrete Removal	SY	185	\$ 32.00	\$ 5,920.00
11	Sod	SY	330	\$ 6.25	\$ 2,062.50
12	Concrete paver driveway reconstruction	SY	360	\$ 36.00	\$ 12,960.00
13	Concrete Curb	LF	75	\$ 22.00	\$ 1,650.00
14	Asphalt Pavement Base & 1st Lift	SY	130	\$ 59.10	\$ 7,683.00
15	Pavement Base Restoration	SY	55	\$ 59.10	\$ 3,250.50
16	Root Pruning	LF	945	\$ 12.00	\$ 11,340.00
17	Swale Regrading	SY	810	\$ 4.25	\$ 3,442.50
18	Thermoplastic, Standard White Solid 24"	LF	55	\$ 5.46	\$ 300.30
19	Thermoplastic, Standard White Solid 12"	LF	100	\$ 2.50	\$ 250.00
20	Thermoplastic, Standard Yellow 6"	LF	300	\$ 1.49	\$ 447.00
21	Manhole-Structure, Ring, Cover	EA	36	\$ 5,383.00	\$ 193,788.00
22	Catch Basin-Structure, Frame, Grate	EA	17	\$ 3,462.00	\$ 58,854.00
23	Exfil. Trench, w/ 18" HDPE slotted pipe including Trench Rest.	LF	2,490	\$ 221.80	\$ 552,282.00
24	HDPE Storm Pipe, 18" including Trench Restoration	LF	1,860	\$ 93.86	\$ 174,579.60
25	Pollution Retardant Baffle	EA	18	\$ 500.00	\$ 9,000.00
26	Manatee Grate	EA	4	\$ 2,350.00	\$ 9,400.00
27	Tideflex Inline Check Valve 24"	EA	4	\$ 11,084.00	\$ 44,336.00
28	Drainage Structure Removal	EA	6	\$ 1,500.00	\$ 9,000.00
29	Drainage Pipe Removal	LF	65	\$ 62.50	\$ 4,062.50
<b>CONTINGENCY ITEMS</b>					
1	Core Drill Existing Structure	EA	1	\$ 2,500.00	
<b>GRAND TOTAL</b>					<b>\$ 1,354,290.40</b>

Refer to pay item notes within contract plans for details of costs to be included within items.

The following Bid Item Notes apply to the bid items:

- Bid Item 1 is a lump sum pay item for all mobilization costs and includes the construction of two (2) project signs that shall be displayed at approaches to the project area. The intent is that the sign will be freestanding. The sign shall display on both sides the project name, Town Logo, elected officials, and contact information. A detail of the sign is included in the plans. Shop drawings must be submitted for approval prior to ordering the project sign. Photos of the actual project sign must be submitted for approval prior to installation of the project signs.  
Mobilization will be paid at the following rates:  
a. 10% of contract completion - 25% of Mobilization.  
b. 25% of contract completion - 50% of Mobilization.  
c. 50% of contract completion - 100% of Mobilization.
- Bid Item 2 is a lump sum pay item for a Maintenance of Traffic (MOT) and includes all pedestrian access maintenance. All crosswalks and sidewalks shall remain open and free of obstructions. Temporary painting for roadways and crosswalks shall be maintained throughout the project. Costs shall include the use of flagmen. Contractor to prepare and submit for review a MOT Plan per phase of construction. The MOT plan shall be prepared by an FDOT certified individual. No work shall begin until the MOT plan has been approved by the Town.
- Bid Items 4, 5 and 6 to include a complete stormwater pollution prevention plan (SWPPP). Notice of Intent fees and compliance with any SWPPP reporting. Include furnishing, installation, maintenance, and removal of items.
- Bid Item 4 is a lump sum pay item to furnish, install, maintain, and remove floating turbidity barriers. Contractor to coordinate access to install floating turbidity barrier at outfalls discharging into C-8 Canal prior to the construction of the proposed drainage system. Access through residential properties is not available.
- Bid items 9 and 12 include cost of replacing driveway approaches noted in plans. Any approach damage outside of those noted on the plans will be repaired by the contractor at no additional cost to the Town.
- Bid item 8 is to include final overlay to the extents shown on the plans or lift of asphalt (1.0") to final grade. Pavement overlay to provide smooth and continuous grading through the entire asphalt overlay process to avoid areas of standing water. This item includes final lift of asphalt over all trench restoration. This item includes asphalt required for grading and crown correction.
- Bid Item 10 includes all costs associated with removal and disposal of concrete and includes saw cutting existing concrete.
- Bid Item 11 includes all costs associated to place sod that will match existing pre-construction conditions. Quantity is intended for areas noted for root pruning, driveway construction, or structure installations. Contractor to match type of sod to existing. Additional sod damage outside the proposed installations will be restored by the contractor at no cost to the Town.
- Bid Item 14 includes all costs associated with proposed asphalt pavement to include stabilized subgrade, limerock base, and the first lift of asphalt. The final lift of asphalt is to be included under the asphalt overlay (Bid Item 8).
- Bid Item 15 includes all costs associated with recompacting the base layer and placing the first lift of asphalt. The final lift of asphalt is to be included under the asphalt overlay (Bid Item 8).
- Bid Item 17 includes all costs associated with regrading the swale to allow for the positive drainage off the roadway as depicted on the plans. This bid item also includes any replacement of existing sod in association with the swale regrading. Contractor to match existing type of sod in place.
- Bid Items 18, 19, and 20 include all costs associated with installing signing and thermoplastic pavement markings including temporary pavement markings prior to thermoplastic and RPMs. Costs associated with replacing existing signs damaged as a result of construction will be the responsibility of the contractor.

13. Bid Items 21 and 22 includes all costs associated with installing inlets and manholes, and pipe connections per the plans. These Bid Items include all costs associated with connecting new structures to existing drainage pipes. These Bid Items shall include all associated excavation, protection of trench, management of excavated material, backfill and compaction, new fill, testing, and adjusting new manhole/utility covers per the plans and details. Trench restoration including first lift of asphalt, second lift to be included with overlay.

14. Bid Item 23 and 24 trench restoration includes limerock base as needed and the first 2.5" lift of asphalt (FDOT type SP-9.5, Fine Mix), the second lift to be included with overlay or Temporary Asphalt Pavement. Surface treated pavement joints shall be lapped and feathered. Pavement restoration for longitudinal cuts shall include full lanes width resurfacing for each lane within which the cut extends. Base material shall have a minimum LBR of 100 and is to be placed in maximum 6" layers with each layer thoroughly rolled or tamped to 98% of maximum density (per AASHTO T-180).

15. Bid Item 23 and 24 includes all costs associated with installing HDPE pipe, exfiltration trench, trench excavation, protection of trench, use of trench box, management of excavated material, new subbase as needed, complete trench backfill and compaction, testing, repair/replacement of site damage such as curbing, drop curb, and sidewalk impacted by construction per the plans and details.

16. Contingency Bid Items 1 are for unit pricing and are not to be included in the grand total.

General Notes:

Staging Area Limitation:

- Due to limited space, contractors are required to carefully strategize material delivery, removal, and other activities to minimize disruption to residents.
- Material Delivery: Contractors must coordinate material deliveries to ensure efficient use of available staging space and minimize congestion in residential areas.
- Hauling Out Materials: Removal of materials should be scheduled and executed with consideration for resident convenience, avoiding peak times and minimizing noise and disruption.
- Resident Impact Mitigation: Contractors are expected to take all necessary measures to mitigate the impact on residents, including adhering to designated work hours and providing advance notice of any disruptions to driveways, sidewalks, and roadways.
- Work Hours: Construction work shall be conducted between 8:30 AM and 4:30 PM to minimize disturbance to residents.
- Temporary Restoration: Temporary restoration of construction areas may be required for town events or as directed by the Town Project Manager. Contractors must promptly restore affected areas to their original condition as needed.
- Open Trench Length Limitation: No open trench should exceed 500 feet in length to ensure safety and efficient work practices.
- Unrestored areas shall be limited to 500 feet in length. The contractor shall restore up to first lift of asphalt before continuing drainage installations. The contractor may elect to install temporary asphalt at no additional cost to the Town.
- Contractor to inspect project site and take note of existing tree canopy. Any expected tree trimming needs for drainage installations shall be included by the contractor in items 22 and 23. All proposed tree trimming operations shall be coordinate by a certified arborist and a trimming report shall be submitted to the Town for review.

**CONTRACT EXECUTION FORM**

This Contract 2024-19 made this 16 day of August in the year 2024 in an amount not to exceed **\$1,354,290.40** by and between the Town of Miami Lakes, Florida, hereinafter called the "Town," and **Master Road Finishers Corp.**, hereinafter called the "Contractor."

IN WITNESS WHEREOF, the parties have executed this Agreement as of the day and year first above written.

Attest:

By:   
e Gina M. Inguanzo, Town Clerk  
Victoria Martinez, Deputy Town Clerk

**TOWN OF MIAMI LAKES**

By:   
Edward Pidermann, Town Manager

Legal Sufficiency:

By:   
Lorenzo Cobiella, Deputy Town Attorney

Date: 8/19/24

Signed, sealed, and witnessed in the presence of:

**CONTRACTOR**

Master Road Finishers Corp  
(Contractor's Name)

By: \_\_\_\_\_

By: 

Name: Osvaldo Claro

Title: President

Date: 8/16/24

(\*) In the event that the Contractor is a corporation, there shall be attached the original of the corporate resolution in the form contained in this Section, of the board of the corporation, authorizing the officer who signs the Contract to do so in its behalf.

**CORPORATE RESOLUTION**

WHEREAS, Master Road Finishers Corp. inc. desires to enter into a contract with the Town of Miami Lakes for the purpose of performing the work described in the contract to which this resolution is attached; and

WHEREAS, the Board of Directors at a duly held corporate meeting has considered the matter in accordance with the By-Laws of the corporation;

Now, THEREFORE, BE IT RESOLVED BY THE BOARD OF DIRECTORS that the President,  
(type title of officer)

Oswaldo Claro, is hereby authorized  
(type name of officer)

and instructed to enter into a contract, in the name and on behalf of this corporation, with the Town of Miami Lakes upon the terms contained in the proposed contract to which this resolution is attached and to execute the corresponding performance bond.

DATED this 16<sup>th</sup> day of August, 20 24.

Lilianne Delgado  
Corporate Secretary

(Corporate Seal)



**Certification – Trench Safety Act**

The Bidder/Proposer, by virtue of signing its Submittal/Response, affirms that the Bidder/Proposer is aware of the Trench Safety Act, and will comply with all applicable trench safety standards. Such assurance shall be legally binding on all persons employed by the Bidder and Subcontractors.

The Bidder/Proposer is also obligated to identify the anticipated method and cost of compliance with the applicable trench safety standards.

Bidder/Proposer acknowledges that included in the various items of the proposal and in the total Bid price are costs for complying with the Florida Trench Safety Act. These items are a breakout of the respective items involving trenching and will not be paid separately. They are not to be confused with bid items in the schedule of prices, nor be considered additional Work.

The Bidder further identifies the costs and methods summarized below:

Description	Unit of Measure	Quantity	Unit Price	Extended Price	Method
<u>Exfil Trench</u>	<u>LF</u>	<u>2490</u>	<u>\$221.80</u>	<u>Enter Price</u>	<u>Enter Method</u>
<u>HDPE Storm Pipe</u>	<u>LF</u>	<u>1800</u>	<u>\$93.86</u>	<u>Enter Price</u>	<u>Enter Method</u>
<u>Enter Description</u>	<u>Enter U/M</u>	<u>          </u>	<u>          </u>	<u>Enter Price</u>	<u>Enter Method</u>
<u>Enter Description</u>	<u>Enter U/M</u>	<u>          </u>	<u>          </u>	<u>Enter Price</u>	<u>Enter Method</u>
<u>Enter Description</u>	<u>Enter U/M</u>	<u>          </u>	<u>          </u>	<u>Enter Price</u>	<u>Enter Method</u>

Total \$726,861.60

The Bidder/Proposer shall acknowledge this Bid and certify the above stated by signing and completing the spaces provided below.

Firm's Name: MASTER ROAD FINISHERS CORP.

Signature: 

Printed Name/Title: OSVALDO CLARO/ PRESIDENT

City/State/Zip: MIAMI FL 33187

Telephone No.: 305-456-2317

Email Address: OCLARO@MASTERROADFINISHERS.COM

## COMPANY QUALIFICATION QUESTIONNAIRE

Some responses may require the inclusion of separate attachments. Separate attachments should be as concise as possible, while including the requested information. In no event should the total page count of all attachments to this Form exceed five (5) pages. Some information may not be applicable, in such instances insert "N/A".

1. How many years has your company been in business under its current name and ownership?

8 years

- a. Professional Licenses/Certifications (include name and license#) \*

Issuance Date

Underground Utility & Excavation  
CUC 1225161

2-09-23

(\*include active certifications of small or disadvantage business & name of certifying entity)

2. Type of Company:  Individual  Partnership  Corporation  LLC  Other  
If other, please describe the type of company: \_\_\_\_\_

- a. FEIN/EIN Number:

47-2674893

- b. Dept. of Business Professional Regulation Category (DBPR):

Cert Under

- i. Date Licensed by DBPR: 06/18/2014

- ii. License Number:

CUC1225161

- c. Date registered to conduct business in the State of Florida:

01-28-2016

- i. Dated filed:

12-29-2014

- ii. Document Number:

P14000102319

- d. Primary Office Location:

18400 SW 202 St Miami FL 33187

- e. What is your primary business?

Master Road Finishers

(This answer should be specific)

- f. Name of Qualifier, license number, and relationship to company:

Jerez, Jose Angel CUC1225161 Qualifier.

g. Names of previous Qualifiers during the past five (5) years including, license numbers, relationship to company and years as qualifier for the company:

Mena Julio - CTQB

---



---

h. Name and Licenses of any prior companies

Name of Company      License Name & No.      Issuance Date

---



---



---

3. Company Ownership

a. Identify all owners or partners of the company:

Name	Title	% of ownership
<u>Oswaldo Claro</u>	<u>President</u>	<u>100%</u>

---



---

b. Is any owner identified above an owner in another company?  Yes  No

If yes, identify the name of the owner, other company names, and % ownership.

---



---

c. Identify all individuals authorized to sign for the company, indicating the level of their authority (check applicable boxes and for other provide specific levels of authority)

Name	Title	Signatory Authority			
		All	Cost	No-Cost	Other
<u>Oswaldo Claro</u>	<u>President</u>	<input checked="" type="checkbox"/>	<input type="checkbox"/>	<input type="checkbox"/>	<input type="checkbox"/>
_____	_____	<input type="checkbox"/>	<input type="checkbox"/>	<input type="checkbox"/>	<input type="checkbox"/>
_____	_____	<input type="checkbox"/>	<input type="checkbox"/>	<input type="checkbox"/>	<input type="checkbox"/>

Explanation for Other: \_\_\_\_\_

4. Employee Information

- a. Total No. of Employees: 11
- b. Total No. of Managerial/Admin. Employees: 2
- c. Number of Trades Personnel and total number per classification:  
(Apprentices must be listed separately for each classification)

---

---

---

5. Will a Labor Force Company be used to provide any workers?  Yes  No

6. Employer Modification Rating: \_\_\_\_\_

7. Insurance & Bond Information:

a. Insurance Carrier name & address:

XI Insurance of America

b. Insurance Contact Name, telephone, & e-mail:

Kristal Massana 305-630-4777 kmassana@ggaig.com

c. Insurance Experience Modification Rating (EMR): 5/10/25

(if no EMR rating please explain why)

d. Number of Insurance Claims paid out in last 5 years & value: 0

e. Bond Carrier name & address:

ACRISURE - 15050 NW 79 Court Suite 200  
Miami FL 33016

f. Bond Carrier Contact Name, Telephone number, & Email:

Mike Megahan - 305-722-2681 mmegahan@acrisure.com

g. Number of Bond Claims paid out in the last 5 years & value of each:

---

---

---

8. Have any lawsuits been filed against your company in the past 5 years?  Yes  No

If yes, in a separate attachment, identify each lawsuit and its current disposition. For each lawsuit provide its case number, venue, the year the suit was filed, the basis for the claim or judgment, its current disposition and, if applicable, the settlement unless the value of the settlement is covered by a written confidentiality agreement.

9. To the best of your knowledge, is your company or any officers of your company currently under investigation by any law enforcement agency or public entity.  Yes  No

If yes, in a separate attachment, provide details including the identity of the officer and the nature of the investigation.

10. Have any Key Staff or Principals (including stockholders with over 10% ownership) of the company been convicted by a Federal, State, County or Municipal Court of or do any Key Staff or Principals have any pending violations of law, other than traffic violations?  Yes  No

If yes, in a separate attachment, provide an explanation of any convictions or pending action including the name of the Key Staff member or Principal involved and the nature of the offense.

11. Has your company been assessed liquidated damages or defaulted on a project in the past five (5) years?  Yes  No If yes, in a separate attachment provide an explanation including the name of the project, the circumstances of default or assessed damages, and the ultimate disposition of the issue.

12. Has the Bidder or any of its principals failed to qualify as a responsible Bidder, refused to enter into a contract after an award has been made, failed to complete a contract during the past five (5) years, or been declared to be in default in any contract in the last five (5) years?  Yes  No

If yes, in a separate attachment provide an explanation including the year, the name of the awarding agency, and the circumstances leading to default.

13. Has the Bidder or any of its principals ever been declared bankrupt or reorganized under Chapter 11 or put into receivership?  Yes  No

If yes, in a separate attachment provide the date, court jurisdiction, action taken, and any other explanation deemed necessary.

14. Project Management & Subcontract Details:

a. Name the Project Manager ("PM") for this Project: Gio Diaz

b. How many years has the PM been with the Company? 5 years

c. List all the PM's licenses & certifications:

---

---

---

d. List the last five (5) projects the PM worked on with the company. In a separate attachment, include the PM's role, scope of work, & value of each project.

Chloe's Estate - \$1,240,000.00 - water, sewer Paving & Drainage

Zona west - \$2M, water, sewer Paving & Drainage

Honey Hill - \$1,100,000.00 water & sewer

Bella Marie - \$678,517.08 water & sewer

e. List all Subcontractors that will work on this project:

Name	Trade/Work	% of Work	License No.
<u>N/A</u>			

f. Scope of Actual Work to be Performed by your company and corresponding percentage of the work:

100%

---

---

---

15. Current and Prior Experience:

a. Current Experience

Provide an attachment to this questionnaire that lists all current projects or contracts, recently awarded, or pending award, including the owner's name, title and value of project, scope of work, projected or actual start date, projected completion date.

b. Prior contracts or projects of a similar size, scope, and complexity:

Provide an attachment to this Questionnaire that includes contracts or projects the Bidder considers of a similar size, scope, and complexity that the Town should consider in determining the Bidders responsiveness and responsibility. This attachment must include the contracts or

projects that meet the minimum number of contracts or projects identified in Section A of the solicitation.

Information provided must include the owner's name, address, and contract person, including telephone & e-mail, title of contract or project, location of project, scope, initial value and final cost of the contract or project, projected and final timeframes for completion in calendar days. A verifiable reference letter is to be completed by the owner of the Project and submitted as part of the Bid submission. Bidders must use Form CRL for its reference letters.

c. Equipment Inventory List

Provide an attachment to this Questionnaire that includes: the make, model, and manufactured year of the inventoried equipment to adequately adhere to the equipment requirements as stated in Section C1.07 of the ITB. All equipment must be in optimum condition to be used to its maximum capacity if deemed necessary.

By signing below, Proposer certifies that the information contained herein is true and accurate to the best of Proposer's knowledge.

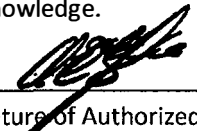
By:   
Signature of Authorized Officer

7-8-24  
Date

Divaldo Claro  
Printed Name

**CLIENT REFERENCE LETTER**

To Whom It May Concern,

Subject: Reference Letter for Bid No. 2024-19 LOCH LOMOND NORTH DRAINAGE IMPROVEMENT PROJECT

Name of Bidder: MASTER ROAD FINISHERS, CORP.

The above-referenced contractor is submitting a bid solicitation that has been issued by the Town. We require that the Bidder provide written references with their Bid submission and by providing you with this document the Contractor requests that you provide the following reference information. We would appreciate you providing the information requested below as well as any other information your feel is pertinent:

Name of Project: HONEYHILL

Name of Project Owner: CITY OF NORTH MIAMI BEACH

Scope of work: DRAINAGE, PAVING & GRADING WATER & SEWER

Value of Project: \$1,331,229.00 Is construction ongoing?  Yes  No

Value of Construction: \$ \_\_\_\_\_ If no, was construction completed on time?  Yes  No

Delivery Method:  Design-Bid-Build  CM @ Risk  Design-Build  Other: \_\_\_\_\_

Was Construction completed within budget?  Yes  No

Did the Contractor contribute to any delay(s) or increased cost?  Yes  No

Causes for Delays or Cost Increases:  Design  Contractor  Owner  Regulatory  N/A

Management of Subcontractors:  Above expectations  Average  Below expectations

Project Safety Management:  Above expectations  Average  Below expectations

Was the Contractor responsive to the Project Owner?  Yes  No

Was the Contractor timely with reviews and submittals?  Yes  No

Number of Change Orders: 7 Were any Contractor driven?  Yes  No

Would you enter into a contract with the Contractor again in the future?  Yes  No

If no to any of the above, please provide details below. Provide any other comment you feel appropriate.

\_\_\_\_\_  
\_\_\_\_\_

Thank you for your assistance in helping us in evaluating our bid solicitation.

Name of individual completing this form: Carlos Vindel Date: 07/31/2024

Signature:  Title: PROJECT MANAGER

Telephone: 414-534-4224 E-mail: \_\_\_\_\_

Sincerely,

Nathalie Garcia,

Procurement Manager

**CLIENT REFERENCE LETTER**

To Whom It May Concern,

Subject: Reference Letter for Bid No. 2024-19 LOCH LOMOND NORTH DRAINAGE IMPROVEMENT PROJECT

Name of Bidder: MASTER ROAD FINISHERS CORP.

The above-referenced contractor is submitting a bid solicitation that has been issued by the Town. We require that the Bidder provide written references with their Bid submission and by providing you with this document the Contractor requests that you provide the following reference information. We would appreciate you providing the information requested below as well as any other information your feel is pertinent:

Name of Project: CITY HALL ANNEX GYM AND COMMUNITY CENTER

Name of Project Owner: CITY OF LAUDERHILL

Scope of work: DRAINAGE, PAVING & GRADING

Value of Project: \$ \_\_\_\_\_ Is construction ongoing?  Yes  No

Value of Construction: \$ \_\_\_\_\_ If no, was construction completed on time?  Yes  No

Delivery Method:  Design-Bid-Build  CM @ Risk  Design-Build  Other: \_\_\_\_\_

Was Construction completed within budget?  Yes  No

Did the Contractor contribute to any delay(s) or increased cost?  Yes  No

Causes for Delays or Cost Increases:  Design  Contractor  Owner  Regulatory  N/A

Management of Subcontractors:  Above expectations  Average  Below expectations

Project Safety Management:  Above expectations  Average  Below expectations

Was the Contractor responsive to the Project Owner?  Yes  No

Was the Contractor timely with reviews and submittals?  Yes  No

Number of Change Orders: \_\_\_\_\_ Were any Contractor driven?  Yes  No

Would you enter into a contract with the Contractor again in the future?  Yes  No

If no to any of the above, please provide details below. Provide any other comment you feel appropriate.

\_\_\_\_\_  
\_\_\_\_\_

Thank you for your assistance in helping us in evaluating our bid solicitation.

Name of individual completing this form: Richard Brown Date: 07/31/2024

Signature: 

Title: CITY OF LAUDERHILL- Project Manager

Telephone: (954) 665-7520

E-mail: rbrown@engenuitygroup.com

Sincerely,

Nathalie Garcia,

Procurement Manager

CLIENT REFERENCE LETTER

To Whom It May Concern,

Subject: Reference Letter for Bid No. 2024-19 LOCH LOMOND NORTH DRAINAGE IMPROVEMENT PROJECT

Name of Bidder: Master Road Finishers Corp.

The above-referenced contractor is submitting a bid solicitation that has been issued by the Town. We require that the Bidder provide written references with their Bid submission and by providing you with this document the Contractor requests that you provide the following reference information. We would appreciate you providing the information requested below as well as any other information your feel is pertinent:

Name of Project: Zona West

Name of Project Owner: Jett Fernandez

Scope of work: Drainage, Paving & Grading, water

Value of Project: \$ 2 ML Is construction ongoing? [x] Yes [ ] No

Value of Construction: \$ \_\_\_\_\_ If no, was construction completed on time? [x] Yes [ ] No

Delivery Method: [ ] Design-Bid-Build [ ] CM @ Risk [ ] Design-Build [ ] Other: \_\_\_\_\_

Was Construction completed within budget? [x] Yes [ ] No

Did the Contractor contribute to any delay(s) or increased cost? [ ] Yes [x] No

Causes for Delays or Cost Increases: [ ] Design [ ] Contractor [ ] Owner [ ] Regulatory [x] N/A

Management of Subcontractors: [ ] Above expectations [ ] Average [ ] Below expectations

Project Safety Management: [x] Above expectations [ ] Average [ ] Below expectations

Was the Contractor responsive to the Project Owner? [x] Yes [ ] No

Was the Contractor timely with reviews and submittals? [x] Yes [ ] No

Number of Change Orders: \_\_\_\_\_ Were any Contractor driven? [ ] Yes [ ] No

Would you enter into a contract with the Contractor again in the future? [x] Yes [ ] No

If no to any of the above, please provide details below. Provide any other comment you feel appropriate.

Thank you for your assistance in helping us in evaluating our bid solicitation.

Name of individual completing this form: Jett Fernandez Date: 7-8-24

Signature: [Signature] Title: Project Manager

Telephone: 305-342-3827 E-mail: Jett@habitatcreators.com

Sincerely,
Nathalie Garcia,
Procurement Manager

CLIENT REFERENCE LETTER

To Whom It May Concern,

Subject: Reference Letter for Bid No. 2024-19 LOCH LOMOND NORTH DRAINAGE IMPROVEMENT PROJECT

Name of Bidder: Master Road Finishers

The above-referenced contractor is submitting a bid solicitation that has been issued by the Town. We require that the Bidder provide written references with their Bid submission and by providing you with this document the Contractor requests that you provide the following reference information. We would appreciate you providing the information requested below as well as any other information your feel is pertinent:

Name of Project: (RPQ) NO. 20190132 (MCC 3040 Plan) Drainage Improvement Multiple Sites

Name of Project Owner: Department of Transportation and Public Works

Scope of work: Installation of drainage structures, French Drain, regrade Swale

Value of Project: \$ 364,439.96 Is construction ongoing?  Yes  No

Value of Construction: \$ \_\_\_\_\_ If no, was construction completed on time?  Yes  No

Delivery Method:  Design-Bid-Build  CM @ Risk  Design-Build  Other: \_\_\_\_\_

Was Construction completed within budget?  Yes  No

Did the Contractor contribute to any delay(s) or increased cost?  Yes  No

Causes for Delays or Cost Increases:  Design  Contractor  Owner  Regulatory  N/A

Management of Subcontractors:  Above expectations  Average  Below expectations

Project Safety Management:  Above expectations  Average  Below expectations

Was the Contractor responsive to the Project Owner?  Yes  No

Was the Contractor timely with reviews and submittals?  Yes  No

Number of Change Orders: 0 Were any Contractor driven?  Yes  No

Would you enter into a contract with the Contractor again in the future?  Yes  No

If no to any of the above, please provide details below. Provide any other comment you feel appropriate.

\_\_\_\_\_  
\_\_\_\_\_

Thank you for your assistance in helping us in evaluating our bid solicitation.

Name of individual completing this form: Jose Gutierrez Date: 3-29-24

Signature: Road Construction Engineer Title: Engineer

Telephone: 305-608-9710 E-mail: Jose.Gutierrez22@MiamiDade.gov

Sincerely,  
Nathalie Garcia,  
Procurement Manager

CLIENT REFERENCE LETTER

To Whom It May Concern,

Subject: Reference Letter for Bid No. 2024-19 LOCH LOMOND NORTH DRAINAGE IMPROVEMENT PROJECT

Name of Bidder: Master Road Finishers

The above-referenced contractor is submitting a bid solicitation that has been issued by the Town. We require that the Bidder provide written references with their Bid submission and by providing you with this document the Contractor requests that you provide the following reference information. We would appreciate you providing the information requested below as well as any other information your feel is pertinent:

Name of Project: RFP NO: 11084A Bids 850 AAR Parking Lot Drainage Improvements Miami International Airport Bldg 850  
Name of Project Owner: Miami-Dade County Aviation Dept.

Scope of work: Installation of exfiltration trench & repaving & stripping

Value of Project: \$332,914.75 Is construction ongoing?  Yes  No

Value of Construction: \$ \_\_\_\_\_ If no, was construction completed on time?  Yes  No

Delivery Method:  Design-Bid-Build  CM @ Risk  Design-Build  Other: \_\_\_\_\_

Was Construction completed within budget?  Yes  No

Did the Contractor contribute to any delay(s) or increased cost?  Yes  No

Causes for Delays or Cost Increases:  Design  Contractor  Owner  Regulatory  N/A

Management of Subcontractors:  Above expectations  Average  Below expectations

Project Safety Management:  Above expectations  Average  Below expectations

Was the Contractor responsive to the Project Owner?  Yes  No

Was the Contractor timely with reviews and submittals?  Yes  No

Number of Change Orders: 0 Were any Contractor driven?  Yes  No

Would you enter into a contract with the Contractor again in the future?  Yes  No

If no to any of the above, please provide details below. Provide any other comment you feel appropriate.

\_\_\_\_\_  
\_\_\_\_\_

Thank you for your assistance in helping us in evaluating our bid solicitation.

Name of individual completing this form: Patricia Gomez Date: 7-29-201

Signature: Patricia Gomez Title: Construction Manager

Telephone: 305-794-2808 E-mail: Phomez@Flymia.com

Sincerely,

Nathalie Garcia,

Procurement Manager

**CLIENT REFERENCE LETTER**

To Whom It May Concern,

Subject: Reference Letter for Bid No. 2024-19 LOCH LOMOND NORTH DRAINAGE IMPROVEMENT PROJECT

Name of Bidder: Master Road Finishers Corp.

The above-referenced contractor is submitting a bid solicitation that has been issued by the Town. We require that the Bidder provide written references with their Bid submission and by providing you with this document the Contractor requests that you provide the following reference information. We would appreciate you providing the information requested below as well as any other information your feel is pertinent:

Name of Project: Atlantic Village III

Name of Project Owner: Atlantic Village 3, LLC

Scope of work: Water, Sewer, Drainage

Value of Project: \$ 592,000 Is construction ongoing?  Yes  No

Value of Construction: \$ \_\_\_\_\_ If no, was construction completed on time?  Yes  No

Delivery Method:  Design-Bid-Build  CM @ Risk  Design-Build  Other: \_\_\_\_\_

Was Construction completed within budget?  Yes  No

Did the Contractor contribute to any delay(s) or increased cost?  Yes  No

Causes for Delays or Cost Increases:  Design  Contractor  Owner  Regulatory  N/A

Management of Subcontractors:  Above expectations  Average  Below expectations

Project Safety Management:  Above expectations  Average  Below expectations

Was the Contractor responsive to the Project Owner?  Yes  No

Was the Contractor timely with reviews and submittals?  Yes  No

Number of Change Orders: \_\_\_\_\_ Were any Contractor driven?  Yes  No

Would you enter into a contract with the Contractor again in the future?  Yes  No

If no to any of the above, please provide details below. Provide any other comment you feel appropriate.

\_\_\_\_\_  
\_\_\_\_\_

Thank you for your assistance in helping us in evaluating our bid solicitation.

Name of individual completing this form: Alberto Cohen . Date: 7-29-24

Signature: \_\_\_\_\_ Title: Project manager

Telephone: 786 202 3262 E-mail: alberto.cohen@gnpo-eco.com

Sincerely,  
Nathalie Garcia,  
Procurement Manager

### CLIENT REFERENCE LETTER

To Whom It May Concern,

Subject: Reference Letter for Bid No. 2024-19 LOCH LOMOND NORTH DRAINAGE IMPROVEMENT PROJECT

Name of Bidder: Master Road Finishers Corp.

The above-referenced contractor is submitting a bid solicitation that has been issued by the Town. We require that the Bidder provide written references with their Bid submission and by providing you with this document the Contractor requests that you provide the following reference information. We would appreciate you providing the information requested below as well as any other information your feel is pertinent:

Name of Project: Bella Marie

Name of Project Owner: Yancey Holding LLC

Scope of work: Water, Sewer, Paving & Grading, Drainage

Value of Project: \$ 678,517.08 Is construction ongoing?  Yes  No

Value of Construction: \$ \_\_\_\_\_ If no, was construction completed on time?  Yes  No

Delivery Method:  Design-Bid-Build  CM @ Risk  Design-Build  Other: \_\_\_\_\_

Was Construction completed within budget?  Yes  No

Did the Contractor contribute to any delay(s) or increased cost?  Yes  No

Causes for Delays or Cost Increases:  Design  Contractor  Owner  Regulatory  N/A

Management of Subcontractors:  Above expectations  Average  Below expectations

Project Safety Management:  Above expectations  Average  Below expectations

Was the Contractor responsive to the Project Owner?  Yes  No

Was the Contractor timely with reviews and submittals?  Yes  No

Number of Change Orders: \_\_\_\_\_ Were any Contractor driven?  Yes  No

Would you enter into a contract with the Contractor again in the future?  Yes  No

If no to any of the above, please provide details below. Provide any other comment you feel appropriate.

\_\_\_\_\_  
\_\_\_\_\_

Thank you for your assistance in helping us in evaluating our bid solicitation.

Name of individual completing this form: Norexa Henriquez Date: 7/18/2024

Signature:  Title: MGR

Telephone: (305) 890 9545 E-mail: Norexa2023@hotmail.com

Sincerely,  
Nathalie Garcia,  
Procurement Manager

**CLIENT REFERENCE LETTER**

To Whom It May Concern,

Subject: Reference Letter for Bid No. 2024-19 LOCH LOMOND NORTH DRAINAGE IMPROVEMENT PROJECT

Name of Bidder: Master Road Finishers Corp.

The above-referenced contractor is submitting a bid solicitation that has been issued by the Town. We require that the Bidder provide written references with their Bid submission and by providing you with this document the Contractor requests that you provide the following reference information. We would appreciate you providing the information requested below as well as any other information your feel is pertinent:

Name of Project: Chloe's Estate

Name of Project Owner: Dupree Holdings LLC

Scope of work: Water & Sewer Paving & Grading, Drainage

Value of Project: \$1.240 M Is construction ongoing?  Yes  No

Value of Construction: \$ \_\_\_\_\_ If no, was construction completed on time?  Yes  No

Delivery Method:  Design-Bid-Build  CM @ Risk  Design-Build  Other: \_\_\_\_\_

Was Construction completed within budget?  Yes  No

Did the Contractor contribute to any delay(s) or increased cost?  Yes  No

Causes for Delays or Cost Increases:  Design  Contractor  Owner  Regulatory  N/A

Management of Subcontractors:  Above expectations  Average  Below expectations

Project Safety Management:  Above expectations  Average  Below expectations

Was the Contractor responsive to the Project Owner?  Yes  No

Was the Contractor timely with reviews and submittals?  Yes  No

Number of Change Orders: 2 Were any Contractor driven?  Yes  No

Would you enter into a contract with the Contractor again in the future?  Yes  No

If no to any of the above, please provide details below. Provide any other comment you feel appropriate.

Thank you for your assistance in helping us in evaluating our bid solicitation.

Name of individual completing this form: Reginald Desarnes Date: 7-18-2024

Signature: [Signature] Title: Development Director

Telephone: 305-979-0473 E-mail: SouthFLbuilders@gmail.com

Sincerely,  
Nathalie Garcia,  
Procurement Manager

**PROJECT MANAGER:** Gio Diaz 786-498-3701

<b>CUSTOMER:</b>	<b>PROJECT</b>			
CONTACT,PHONE	PROJECT NAME LOCATION	DESCRIPTION	CONTRACT AMOUNT	YEAR COMPLETED
JETT FERNANDEZ 305-342-3827	ZONA WEST	DRAINAGE, WATER &SEWER, PAVING & GRADING	\$2 ML	2024
REY DESARMES 786-601-7928	CHLOE'S ESTATE	DRAINAGE, WATER &SEWER, PAVING & GRADING	\$1,240,000.00	2024
CARLOS VINDEL- 414-534-4224	HONEY HILL	DRAINAGE, WATER &SEWER, PAVING & GRADING	\$1,160,000.00	2023
ELISA HERMIDA-786-656-3400	BELLA MARIE	DRAINAGE, WATER &SEWER, PAVING & GRADING	\$678,517.08	2022
EDUARDO FRIEDMAN-305-677-3700 EXT 506	AV4	DRAINAGE, WATER &SEWER, PAVING & GRADING	\$440,285.00	2024

**ADDENDUM ACKNOWLEDGEMENT FORM**

Solicitation No.: ITB NO. 2024-19

Listed below are the dates of issue for each Addendum received in connection with this Solicitation:

Addendum No. <u># 1</u>	Dated <u>6/26/24</u>
Addendum No. <u>#2</u>	Dated <u>7/2/24</u>
Addendum No. _____	Dated _____
Addendum No. _____	Dated _____
Addendum No. _____	Dated _____
Addendum No. _____	Dated _____
Addendum No. _____	Dated _____
Addendum No. _____	Dated _____
Addendum No. _____	Dated _____
Addendum No. _____	Dated _____

No Addendum issued for this Solicitation

Firm's Name: Master Road Finishers Corp.

Authorized Representative's Name: Dsvaldo Oluro

Title: President

Authorized Signature: 



## ITB 2024-19

### Loch Lomond North Drainage Improvement Project

#### Addendum #1

**Due Date: 11:00 AM EST, JULY 11, 2024**

This addendum is incorporated into and made a part of the Invitation to Bid (“ITB”). The following may include clarifications, revisions, additions, deletions, or answers to questions received relative to the ITB, which take precedence over the ITB documents. Underlined word(s) indicate additions. Deletions are indicated by strikethrough.

#### Clarifications/Additions:

1. Updated Plans 06-25-2024
2. Updated Bid Form 06-25-2024
3. Geotechnical Report
4. Survey

#### Questions:

1. The plans call for several removals of existing structures, but there is no bid item for it. Would this be added?  
**Response: Yes, Bid Item 28 added for existing drainage structure removal.**
2. The plans call for several “connections to existing pipes”, but there is no bid item for it. Would this be added?  
**Response: No, Bid Note #13 states that Bid items 21 and 22 include “all costs associated with installing inlets and manholes, and pipe connections per the plans. These Bid Items include all costs associated with connecting new structure to existing drainage pipes.”**
3. The plans call for “connecting to existing pipes”, but there is not bid items for 24’ SOLID PIPE & 15” SOLID PIPE? Would these items be added?  
**Response: No, Bid Note #13 states that “These Bid Items include all costs associated with connecting new structure to existing drainage pipes.”**
4. Please revise the sod area to include the swale area if the plans indicate the need for reshaping the swale.



**Response: Bid Item Notes for Bid items 11 and 17 added to address questions regarding swale area and sod. (Bid Notes #8 and Bid Note #11).**

5. What is the minimum required length for the turbidity barrier? The plans currently specify 100 feet, based on a 25-foot turbidity barrier for each of the 4 outfalls.

**Response: Bid item updated from LF to LS since contractor will be responsible for their SWPPP. OPC updated to reflect the change from LF to LS. (The typical Floating Turbidity Barrier length is 50 LF; however, there are manufacturers that make 25 LF floating turbidity barriers.)**

6. Please review and confirm the area designated for pavers, in response to the contractor's inquiry.

**Response: The area designated for pavers is confirmed. The contractor asked if the driveways needed to be replaced if there is no proposed drainage in the area. Yes, the pavers need to be replaced to regrade the area. (For example: in the cul-de-sac on sheet C300.2)**

7. Please specify the requirements for asphalt removal, particularly for asphalt driveways.

**Response: Bid Note #9 was added to address asphalt pavement requirements, which includes subbase, base, and fist lift of asphalt. Additionally, plans were updated to include pavement cross-section detail on sheet C301.3. Bid Note #10 was added to describe the requirements for pavement base restoration.**

8. What is the Contract Time?

**Response: Per Section D2 of the ITB, the Contractor shall obtain Substantial Completion of the Work within three hundred (300) Days of the Notice to Proceed being issued by the Town. Contractor must obtain Final Completion within thirty (30) Days after obtaining Substantial Completion.**

9. What is the budget for this Project?

**Response: Opinion of Probable Cost for this project is approximately \$1,491,000.00.**

10. Could you please specify the standard heights for trimming tree branches?

**Response: Trees are trimmed to a 14.5-foot clearance along the roadway and 10-foot clearance along the sidewalk.**



11. Will an FDOT Qualified Contractor be considered a responsive bidder with these minimum qualifications?

**Response: An FDOT Qualified Contractor would need to meet the minimum technical qualification standards depending on the type of work they intend to perform. These standards are defined by the type of construction work, such as road construction, drainage work, utility work, etc. This includes holding a current license or registration as regulated by the State of Florida, as appropriate. Contractors must demonstrate relevant experience in similar projects and maintain a record of satisfactory performance on previous projects.**

12. Do you have a Survey and Geotechnical Report for this Project?

**Response: Please see attached Geotechnical Report and Survey.**

Acknowledgement:

Dsvaldo Claro  
Name of Signatory  
President  
Title  
7-8-24  
Date

  
Signature  
Master Road Finisher Corp.  
Name of Bidder



**ITB 2024-19**

**Loch Lomond North Drainage Improvement Project**

**Addendum #2**

**Due Date: 11:00 AM EST, JULY 11, 2024**

This addendum is incorporated into and made a part of the Invitation to Bid ("ITB"). The following may include clarifications, revisions, additions, deletions, or answers to questions received relative to the ITB, which take precedence over the ITB documents. Underlined word(s) indicate additions. Deletions are indicated by strikethrough.

**Questions:**

1. The plans call for control structure at cb-1 & cb-10; What are the dimensions of these structures? There is no bid items for these control structures?  
**Response: The control structures will be Miami-Dade County Drainage Structure Type J with inverted baffles and have been accounted for in the catch basin line item on the bid form.**
2. I am reaching out to see if you would be willing to accept Proco Products as an approved alternative to the Tideflex inline check valve. Attached is some detailed information for you.  
**Response: Yes, the use of the Proco valve is acceptable.**
3. We would like to request an extension on the due date for the above project due to addendums sent on June 26th. Please let us know is this is possible.  
**Response: The addendum was posted with sufficient notice for bidders to integrate any updates into their bids. We will maintain the original due date at this time.**

Acknowledgement:

Rivaldo Claro  
Name of Signatory  
President  
Title  
7-8-24  
Date

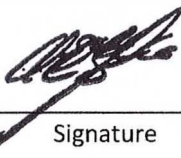
  
\_\_\_\_\_  
Signature  
Master Road Finishers  
Name of Bidder

**SWORN STATEMENT ON PUBLIC ENTITY CRIMES**

**SECTION 287.133(3)(a), FLORIDA STATUTES**

**THIS FORM MUST BE SIGNED AND SWORN TO IN THE PRESENCE OF A NOTARY PUBLIC OR OTHER OFFICIAL AUTHORIZED TO ADMINISTER OATHS.**

1. This sworn statement is submitted to the Town of Miami Lakes

by Dsvaldo Claro - President  
[print individual's name and title]

for Master Road Finishers Corp.  
[print name of entity submitting sworn statement]

whose business address is

18400 Sw 202 St Miami FL 33187

and (if applicable) its Federal Employer Identification Number (FEIN) is 47-2674893

(If the entity has no FEIN, include the Social Security Number of the individual

signing this sworn statement: DC )

2. I understand that a "public entity crime" as defined in Paragraph 287.133(1)9g), Florida Statutes, means a violation of any state or federal law by a person with respect to and directly related to the transaction of business with any public entity or with an agency or political subdivision of any other state or the United States, including, but not limited to, any bid or contract for goods and services to be provided to any public entity or an agency or political subdivision of any other state or of the United States involving antitrust, fraud, theft, bribery, collusion, racketeering, conspiracy, or material misrepresentation.

3. I understand that "convicted" or "conviction" as defined in Paragraph 287.133(1)(b), Florida Statutes, means a finding of guilt or a conviction or a public entity crime, with or without an adjudication of guilt, in any federal or state trial court of record relating to charges brought by indictment or information after July 1, 1989, as a result of a jury verdict, nonjury trial, or entry of a plea of guilty or nolo contendere.

4. I understand than an "affiliate" as defined in Paragraph 287.133(1)(a), Florida Statutes, means:

- a. A predecessor or successor of a person convicted of a public entity crime; or
- b. An entity under the control of any natural person who is active in the management of the entity and who has been convicted of a public entity crime.

The term "affiliate" includes those officers, directors, executives, partners, shareholders, employees, members, and agents who are active in the management of an affiliate. The ownership by one person of shares constituting a controlling interest in another person, or a pooling of equipment or income among persons when not for fair market value under an arm's length agreement, shall be a prima facie case that one person controls another person. A person who knowingly enters into a joint venture with a person who

has been convicted of a public entity crime in Florida during the preceding 36 months shall be considered an affiliate.

5. I understand that a "person" as defined in Paragraph 287.133(1)(e), Florida Statutes, means any natural person or entity organized under the laws of any state or of the United States with the legal power to enter into a binding contract and which bids or applies to bid on contracts for the provision of goods or services let by a public entity, or which otherwise transacts or applies to transact business with a public entity. The term "person" includes those officers, directors, executives, partners, shareholders, employees, members, and agents who are active in the management of an entity.

6. Based on information and belief, the statement that I have marked below is true in relation to the entity submitting this sworn statement. **[Indicate which statement applies.]**

  Neither the entity submitting this sworn statement, nor any officers, directors, executives, partners, shareholders, employees, members, or agents who are active in the management of the entity, not any affiliate of the entity, has been charged with and convicted of a public entity crime subsequent to July 1, 1989.

  This entity submitting this sworn statement, or one or more of its officers, directors, executives, partners, shareholders, employees, members, or agents who are active in the management of the entity, or an affiliate of the entity has been charged with and convicted of a public entity crime subsequent to July 1, 1989.

  The entity submitting this sworn statement, or one or more of its officers, directors, executives, partners, shareholders, employees, members, or agents who are active in the management of the entity, or an affiliate of the entity has been charged with and convicted of a public entity crime subsequent to July 1, 1989. However, there has been a subsequent proceeding before a Hearing Officer of the State of Florida, Division of Administrative Hearings and the Final Order entered by the Hearing Officer determined that it was not in the public interest to place the entity submitting this sworn statement on the convicted vendor list. **[attach a copy of the final order]**

**I UNDERSTAND THAT THE SUBMISSION OF THIS FORM TO THE CONTRACTING OFFICER FOR THE PUBLIC ENTITY IDENTIFIED IN PARAGRAPH 1 ABOVE IS FOR THAT PUBLIC ENTITY ONLY AND, THAT THIS FORM IS VALID THROUGH DECEMBER 31 OF THE CALENDAR YEAR IN WHICH IT IS FILED. I ALSO**

**UNDERSTAND THAT I AM REQUIRED TO INFORM THE PUBLIC ENTITY PRIOR TO ENTERING INTO A CONTRACT IN EXCESS OF THE THRESHOLD AMOUNT PROVIDED IN SECTION 287.017, FLORIDA STATUTES, FOR CATEGORY TWO OF ANY CHANGE IN THE INFORMATION CONTAINED IN THIS FORM.**

BEFORE ME, the undersigned authority, personally appeared    to me well known and known by me to be the person described herein and who executed the foregoing Affidavit and acknowledged to and before me that    executed said Affidavit for the purpose therein expressed.

WITNESS, my hand and official seal this   3   day of   July  ,   24  .

My Commission Expires:   9-4-2027    
  Liliane Delgado    
Notary Public State of Florida at Large

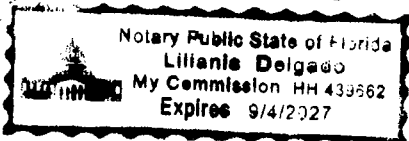



**ANTI-KICKBACK AFFIDAVIT**

STATE OF FLORIDA            }  
  }  
  }        SS:  
COUNTY OF MIAMI-DADE    }

I, the undersigned, hereby duly sworn, depose and say that no portion of the sum herein bid will be paid to any employees of the Town of Miami Lakes, its elected officials, and Osvaldo Claro or its design consultants, as a commission, kickback, reward, or gift, directly or indirectly by me or any member of my firm or by an officer of the corporation.

By: [Signature]  
Title: President

BEFORE ME, the undersigned authority, personally appeared ✓ to me well known and known by me to be the person described herein and who executed the foregoing Affidavit and acknowledged to and before me that \_\_\_\_\_ executed said Affidavit for the purpose therein expressed.

WITNESS, my hand and official seal this 8<sup>th</sup> day of July, 2024

My Commission Expires: 9/4/27  
[Signature]  
Notary Public State of Florida at Large

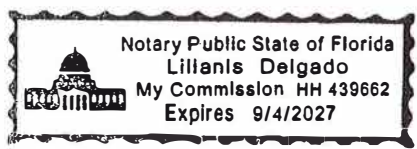



## COMPLIANCE WITH PUBLIC RECORDS LAW

The Town of Miami Lakes shall comply with the Public Records Law as provided by Chapter 119, Florida Statutes, and all applicable amendments. Applicants must invoke the exemptions to disclosure provided by law in the response to the solicitation and must identify the data or other materials to be protected by separate envelope and must state the reasons why such exclusion from public disclosure is necessary. The submission of a response authorizes release of your firm's credit data to the Town of Miami Lakes.

If the company submits information exempt from public disclosure, the company must identify with specificity which pages/paragraphs of their submittal/proposal package are exempt from the Public Records Act, identifying the specific exemption section that applies to each. The protected information must be submitted to the Town in a separate envelope marked "EXEMPT FROM PUBLIC RECORDS LAW". Failure to identify protected material via a separately marked envelopment will cause the Town to release this information in accordance with the Public Records Law despite any markings on individual pages of your submittal/proposal.

- (a) CONTRACTOR acknowledges TOWN'S obligations under Article 1, Section 24, Florida Constitution and Chapter 119, Florida Statutes, to release public records to members of the public upon request. CONTRACTOR acknowledges that TOWN is required to comply with Article 1, Section 24, Florida Constitution and Chapter 119, Florida Statutes, in the handling of the materials created under this Agreement and that said statute controls over the terms of this Agreement.
- (b) CONTRACTOR specifically acknowledges its obligations to comply with Section 119.0701, Florida Statutes, with regard to public records, and shall:
1. Keep and maintain public records that ordinarily and necessarily would be required by TOWN in order to perform the services required under this Agreement;
  2. Provide the public with access to public records on the same terms and conditions that TOWN would provide the records and at a cost that does not exceed the cost provided in Chapter 119, Florida Statutes, or as otherwise provided by law;
  3. Ensure that public records that are exempt or confidential and exempt from public records disclosure requirements are not disclosed, except as authorized by law; and
  4. Meet all requirements for retaining public records and transfer, at no cost to the TOWN, all public records in possession of CONTRACTOR upon termination of this Agreement and destroy any duplicate public records that are exempt or confidential and exempt from public records disclosure requirements. All records stored electronically must be provided to TOWN in a format that is compatible with the information technology system of TOWN.
- (c) Failure to comply with this Section shall be deemed a material breach of this Contract for which TOWN may terminate this Agreement immediately upon written notice to CONTRACTOR.

By submitting a response to this solicitation, the company agrees to defend the Town in the event we are forced to litigate the public records status of the company's documents.

Company Name: Master Road Finishers Corp.

Authorized representative (print): Osvaldo Alberto

Authorized representative (signature):  Date: 7-8-24



**PUBLIC RELATIONS AFFIDAVIT**

Bidder's Name: Master Road Finishers Solicitation No.: ITB NO. 2024-19

By executing this affidavit, Proposer discloses any personal or business relationship or experience with any current Town employee or elected representative of the Town.

Proposer shall disclose to the Town:

- a) Any direct or indirect personal interests in a vendor held by any employee or elected representative of the Town.

\_\_\_\_\_  
Last name First name Relationship

\_\_\_\_\_  
Last name First name Relationship

\_\_\_\_\_  
Last name First name Relationship

- b) Any family relationships with any employee or elected representative of the Town.

\_\_\_\_\_  
Last name First name Relationship

\_\_\_\_\_  
Last name First name Relationship

\_\_\_\_\_  
Last name First name Relationship

  
\_\_\_\_\_  
Authorized Signature

7-8-24  
\_\_\_\_\_  
Date:

Osvaldo Alaro  
\_\_\_\_\_  
Print Name

President  
\_\_\_\_\_  
Title:

### E-VERIFY COMPLIANCE CERTIFICATION

In accordance with County Policy and Executive Order Number 11-116 from the office of the Governor of the State of Florida, Bidder hereby certifies that the U.S. Department of Homeland Security's E-Verify system will be used to verify the employment eligibility of all new employees hired by the contractor during the contract term, and shall expressly require any subcontractors performing work or providing services pursuant to the contract to likewise utilize the U.S. Department of Homeland Security's E-Verify system to verify the employment eligibility of all new employees hired by the subcontractor during the contract term; and shall provide documentation of such verification to the Town upon request.

As the person authorized to sign this statement, I certify that this company complies/will comply fully with the above requirements.

DATE: 7-8-24

SIGNATURE: \_\_\_\_\_



COMPANY: Master Road Finishers Corp.

ADDRESS: 18400 Sw 202 st  
Miami FL 33187

NAME: Osvaldo Claro

TITLE: President

EMAIL: Oclaro@MasterroadFinishers.com

PHONE NO.: 305-456-2317

## DRUG-FREE WORKPLACE CERTIFICATION

Preference shall be given to businesses with drug-free workplace programs. Pursuant to Section 287.087, Florida Statutes, whenever two or more competitive solicitations that are equal with respect to price, quality, and service are received by the State or by any political subdivision for the procurement of commodities or contractual services, a response received from a business that certifies that it has implemented a drug-free workplace program shall be given preference in the award process. Established procedures for processing tie responses will be followed if none of the tied providers has a drug free workplace program. In order to have a drug-free workplace program, a business shall:

1. Publish a statement notifying employees that the unlawful manufacture, distribution, dispensing, possession, or use of a controlled substance is prohibited in the workplace and specifying the actions that will be taken against employees for violations of such prohibition.
2. Inform employees about the dangers of drug abuse in the workplace, the business's policy of maintaining a drug-free workplace, any available drug counseling, rehabilitation, and employee assistance programs, and the penalties that may be imposed upon employees for drug abuse violations.
3. Give each employee engaged in providing the commodities or contractual services that are under proposal a copy of the statement specified in Subsection (1).
4. In the statement specified in Subsection (1), notify the employees that, as a condition of working on the commodities or contractual services that are under proposal, the employee will abide by the terms of the statement and will notify the employer of any conviction of, or plea of guilty or nolo contendere to, any violation of Chapter 894, Florida Statutes, or of any controlled substance law of the United States or any state, for a violation occurring in the workplace no later than five (5) days after such conviction.
5. Impose a sanction on any employee who is so convicted or requires the satisfactory participation in a drug abuse assistance or rehabilitation program as such is available in the employee's community.
6. Make a good faith effort to continue to maintain a drug-free workplace through implementation of applicable laws, rules, and regulations.

As the person authorized to sign the statement, I certify that this firm complies fully with the above requirements.

Master Road Finishers

Company Name:

7-8-24

Date

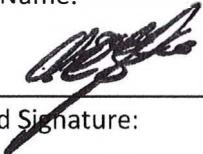
  
Authorized Signature:

Osvaldo Claro

Printed Name and Title

**CONTRACT EXECUTION FORM**

This Contract Oswaldo Claro made this 8<sup>th</sup> day of July in the year 24 in an amount not to exceed \$ 1,354,290.40 by and between the Town of Miami Lakes, Florida, hereinafter called the "Town," and Master Road Finisher hereinafter called the "Contractor."

IN WITNESS WHEREOF, the parties have executed this Agreement as of the day and year first above written.

Attest:

**TOWN OF MIAMI LAKES**

By: \_\_\_\_\_  
Gina M. Inguanzo, Town Clerk

By: \_\_\_\_\_  
Edward Pidermann, Town Manager

Legal Sufficiency:

By: \_\_\_\_\_  
Lorenzo Cobiella, Deputy Town Attorney

Date: \_\_\_\_\_

Signed, sealed, and witnessed in the presence of:

**CONTRACTOR**

Master Road Finishers Corp.  
(Contractor's Name)

By: \_\_\_\_\_

By: \_\_\_\_\_ 

Name: Oswaldo Claro

Title: President

Date: 7-8-24

Section F. (\*) In the event that the Contractor is a corporation, there shall be attached the original of the corporate resolution in the form contained in this Section, of the board of the corporation, authorizing the officer who signs the Contract to do so in its behalf.

CORPORATE RESOLUTION

WHEREAS, Master Road Finishers, Inc. desires to enter into a contract with the Town of Miami Lakes for the purpose of performing the work described in the contract to which this resolution is attached; and

WHEREAS, the Board of Directors at a duly held corporate meeting has considered the matter in accordance with the By-Laws of the corporation;

Now, THEREFORE, BE IT RESOLVED BY THE BOARD OF DIRECTORS that the President,  
(type title of officer)

Oswaldo Claro, is hereby authorized  
(type name of officer)

and instructed to enter into a contract, in the name and on behalf of this corporation, with the Town of Miami Lakes upon the terms contained in the proposed contract to which this resolution is attached and to execute the corresponding performance bond.

DATED this 8<sup>th</sup> day of July, 20 24.

Liliana Delgado  
Corporate Secretary

(Corporate Seal)

Plotted By: Cuzpino, Casey - Sheet Set: LOCH LOMOND NORTH DRAINAGE IMPROVEMENTS - Layout: C200.1 DEMOLITION & EROSION CONTROL PLAN - June 25, 2024 - 05:30:57pm - K:\V\civil\044\_Jobs\04453222\_wof20\_loch lomond n.d\CAD\plansheets\C200.1 DEMOLITION & EROSION CONTROL PLAN.dwg  
 This document, together with the concepts and designs presented herein, is intended only for the specific purpose and client for which it was prepared. Reuse of and improper reliance on this document without written authorization and adaptation by Kimley-Horn and Associates, Inc. shall be without liability to Kimley-Horn and Associates, Inc.

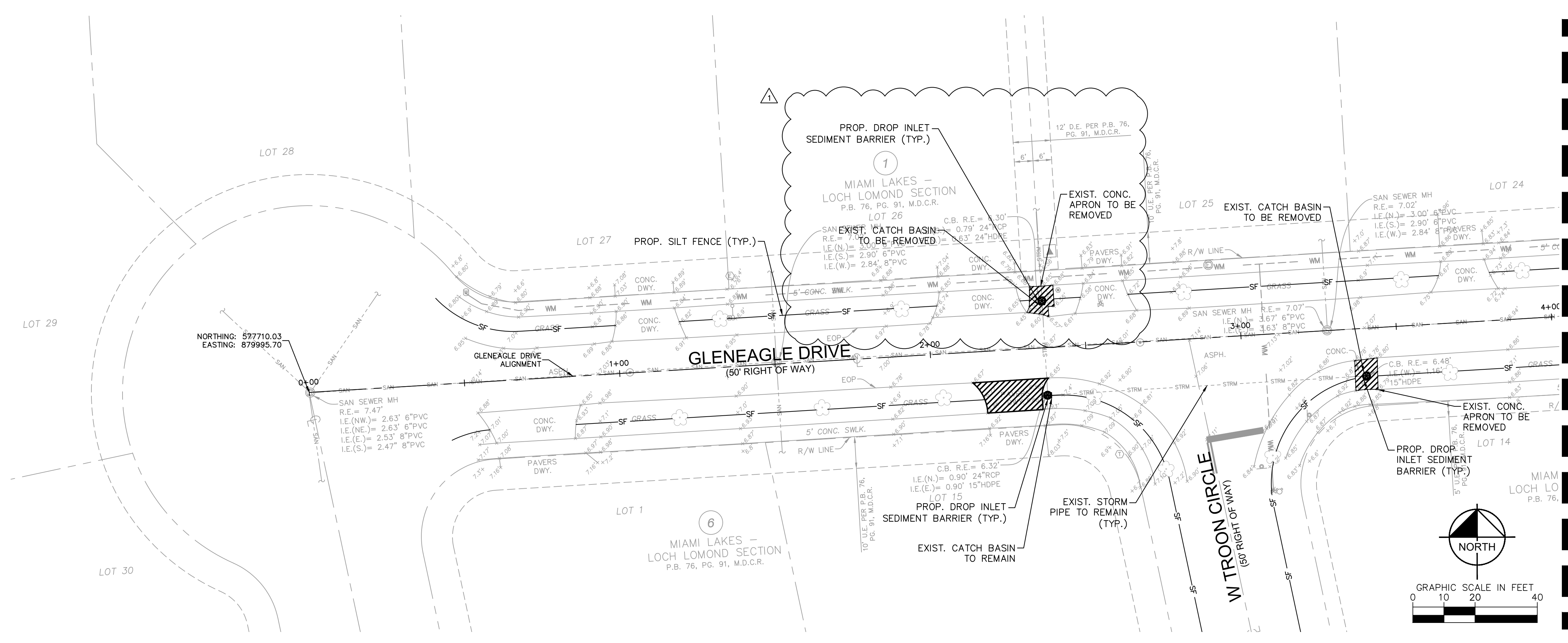

**KEY MAP**

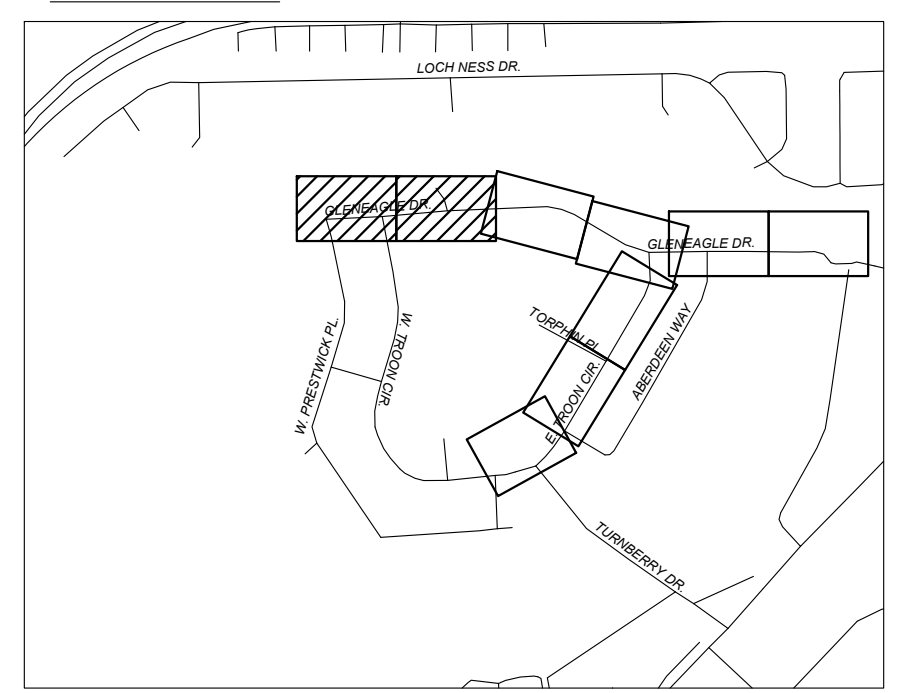

**LEGEND**

- PROPERTY LINE / RIGHT-OF-WAY
- CENTER LINE/ALIGNMENT
- SAN — EXISTING SANITARY SEWER PIPE
- STRM — EXISTING STORM DRAIN PIPE
- WM — EXISTING WATER MAIN PIPE
- SF — EXISTING STORM CATCH BASIN
- SMH — EXISTING STORM MANHOLE
- SSMH — EXISTING SANITARY SEWER MANHOLE
- SIG — EXISTING SIGN
- LPT — EXISTING LIGHTPOLE
- MB — EXISTING MAILBOX
- VAL — EXISTING VALVE
- HYD — EXISTING HYDRANT
- GRD — EXISTING GRADE
- ISB — PROPOSED INLET SEDIMENT BARRIER
- SF — PROPOSED SILT FENCE
- [Hatched Box] — EXISTING TO BE REMOVED
- [Cross-hatched Box] — EXISTING LIMEROCK BASE TO BE REWORKED
- [Diagonal Hatched Box] — EXISTING ASPHALT TO BE MILLED & RESURFACED

**NOTES**

1. ALL AREAS DAMAGED BY THE CONTRACTOR, INCLUDING BUT NOT LIMITED TO PAVEMENT MARKINGS, ASPHALT, SWALE, SIDEWALK, AND DRIVEWAYS, SHALL BE RESTORED, AT THE CONTRACTOR'S EXPENSE, TO ORIGINAL CONDITION. SAW CUTTING OF THE EXISTING SIDEWALK SHALL BE MADE ONLY AT THE NEAREST FLAG JOINTS.
2. NO EXISTING TREES SHALL BE REMOVED UNLESS OTHERWISE SPECIFIED.
3. SHOULD ANY EXISTING TREE BE REQUIRED TO BE REMOVED OR RELOCATED BASED ON PROPOSED WORK, CONTRACTOR TO COORDINATE MODIFIED WORK WITH ENGINEER. SHOULD TREE REMOVAL/RELOCATION BE REQUIRED, CONTRACTOR TO OBTAIN ALL REQUIRED PERMITS.
4. ALL ASPHALT TO BE REMOVED SHALL BE SAW CUT ADJACENT TO REMAINING IMPROVEMENTS.
5. CONTRACTOR TO MAINTAIN DRAINAGE FLOW DURING AND AFTER CONSTRUCTION.
6. ALL EXISTING SIGNS IMPACTED BY CONSTRUCTION SHALL BE MODIFIED/RELOCATED AS NECESSARY AT THE CONTRACTOR'S EXPENSE.
7. ALL TREES ARE TO BE PROTECTED AT ALL TIMES DURING CONSTRUCTION.

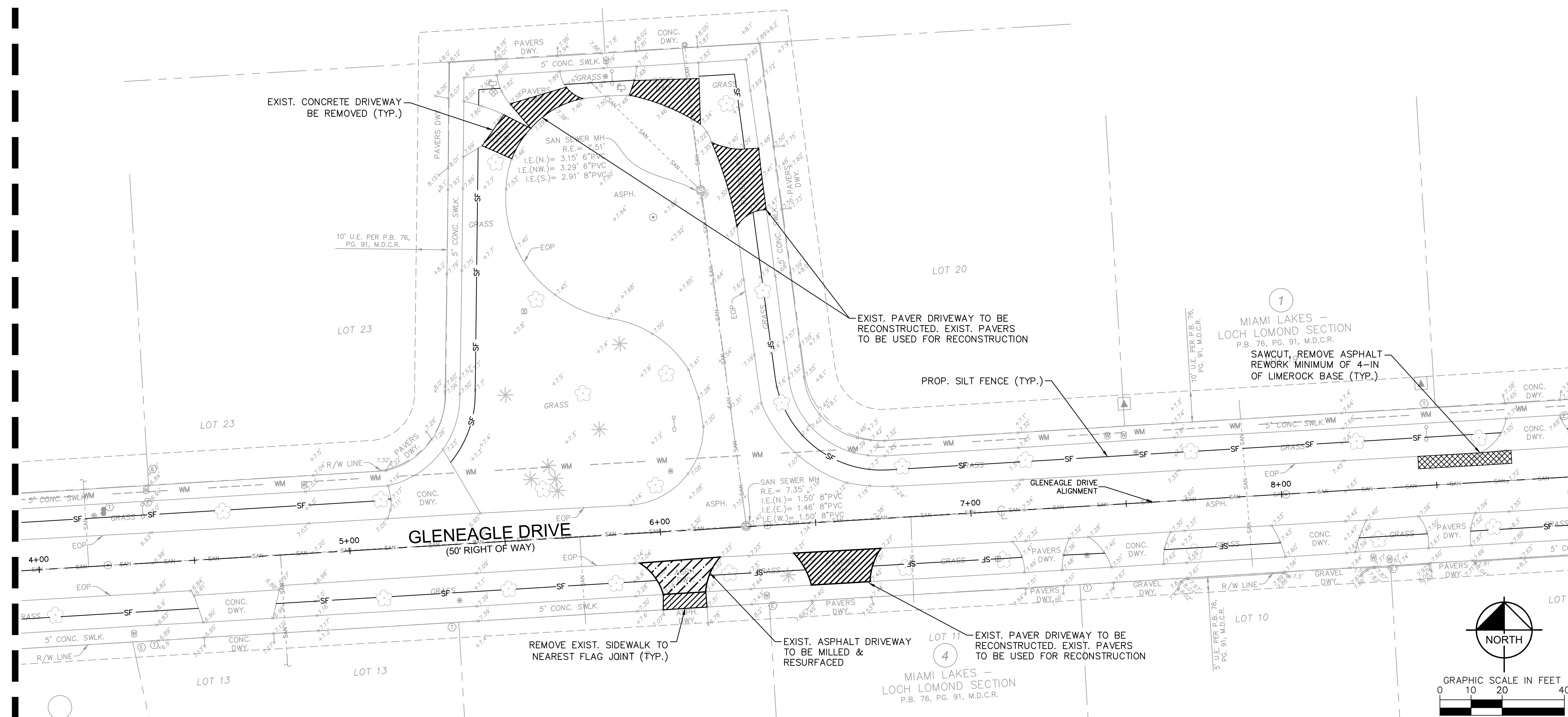

MATCHLINE SEE BOTTOM LEFT FOR CONTINUATION

MATCHLINE SEE SHEET C200.2 FOR CONTINUATION

<b>Kimley»Horn</b>		LICENSED PROFESSIONAL TIFFANY STANTON, P.E. DATE: JUN 2024 SCALE: AS SHOWN DESIGNED BY: TS DRAWN BY: DC CHECKED BY: SV	
© 2024 KIMLEY-HORN AND ASSOCIATES, INC. 8201 PETERS ROAD, SUITE 2200, PLANTATION, FL 33324 PHONE: 954-535-5100 FAX: 954-739-2247 WWW.KIMLEY-HORN.COM REGISTRY No. 35106		DEMO & PGD UPDATES REVISIONS DATE BY	
<b>LOCH LOMOND NORTH DRAINAGE IMPROVEMENTS</b> PREPARED FOR <b>TOWN OF MIAMI LAKES</b> MIAMI LAKES, FLORIDA		SHEET NUMBER <b>C200.1</b>	

Plotted By: Cuzpino, Casey - Sheet Set: LOCH LOMOND NORTH DRAINAGE IMPROVEMENTS - Layout: C200.2 - DEMOLITION & EROSION CONTROL PLAN - June 25, 2024 - 05:31:01pm - K:\VH\civil\044 - Jobs\044533222 - wofz0 loch lomond n.d\CAD\plansheets\C200.1 DEMOLITION & EROSION CONTROL PLAN.dwg  
 This document, together with the concepts and designs presented herein, is intended only for the specific purpose and client for which it was prepared. Reuse of and improper reliance on this document without written authorization and adaptation by Kimley-Horn and Associates, Inc. shall be without liability to Kimley-Horn and Associates, Inc.

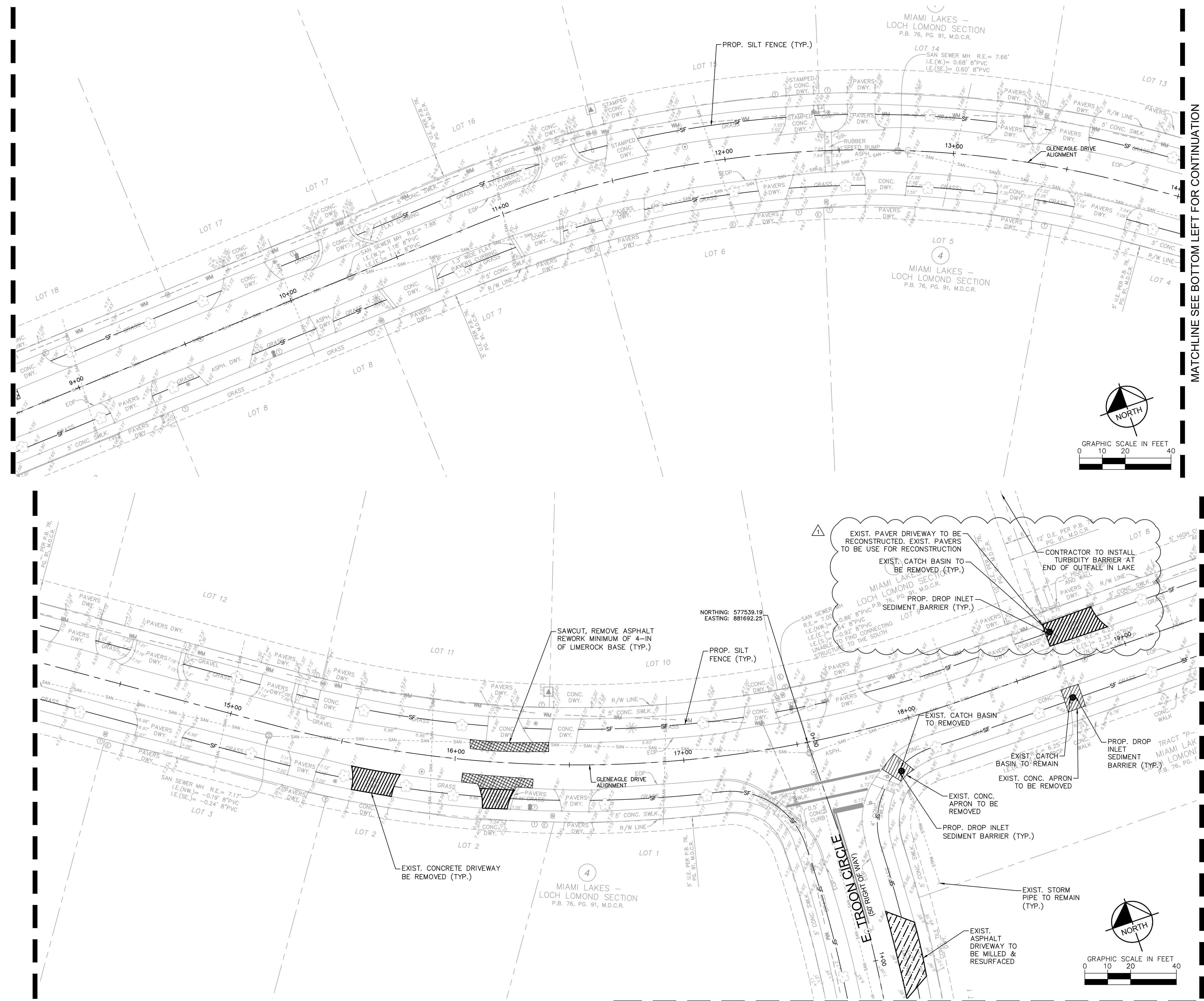

### KEY MAP

### LEGEND

- PROPERTY LINE / RIGHT-OF-WAY
- CENTER LINE / ALIGNMENT
- EXISTING SANITARY SEWER PIPE
- EXISTING STORM DRAIN PIPE
- EXISTING WATER MAIN PIPE
- EXISTING STORM CATCH BASIN
- EXISTING STORM MANHOLE
- EXISTING SANITARY SEWER MANHOLE
- EXISTING SIGN
- EXISTING LIGHTPOLE
- EXISTING MAILBOX
- EXISTING VALVE
- EXISTING HYDRANT
- EXISTING GRADE
- PROPOSED INLET SEDIMENT BARRIER
- PROPOSED SILT FENCE
- EXISTING TO BE REMOVED
- EXISTING LIMEROCK BASE TO BE REWORKED
- EXISTING ASPHALT TO BE MILLED & RESURFACED

- ### NOTES
- ALL AREAS DAMAGED BY THE CONTRACTOR, INCLUDING BUT NOT LIMITED TO PAVEMENT MARKINGS, ASPHALT, SWALE, SIDEWALK, AND DRIVEWAYS, SHALL BE RESTORED, AT THE CONTRACTOR'S EXPENSE, TO ORIGINAL CONDITION. SAW CUTTING OF THE EXISTING SIDEWALK SHALL BE MADE ONLY AT THE NEAREST FLAG JOINTS.
  - NO EXISTING TREES SHALL BE REMOVED UNLESS OTHERWISE SPECIFIED.
  - SHOULD ANY EXISTING TREE BE REQUIRED TO BE REMOVED OR RELOCATED BASED ON PROPOSED WORK, CONTRACTOR TO COORDINATE MODIFIED WORK WITH ENGINEER. SHOULD TREE REMOVAL/RELOCATION BE REQUIRED, CONTRACTOR TO OBTAIN ALL REQUIRED PERMITS.
  - ALL ASPHALT TO BE REMOVED SHALL BE SAW CUT ADJACENT TO REMAINING IMPROVEMENTS.
  - CONTRACTOR TO MAINTAIN DRAINAGE FLOW DURING AND AFTER CONSTRUCTION.
  - ALL EXISTING SIGNS IMPACTED BY CONSTRUCTION SHALL BE MODIFIED/RELOCATED AS NECESSARY AT THE CONTRACTOR'S EXPENSE.
  - ALL TREES ARE TO BE PROTECTED AT ALL TIMES DURING CONSTRUCTION

No.	REVISIONS	DATE	BY
1	DEMOS & PGD UPDATES	6/25/2024	CC

## Kimley & Horn

© 2024 KIMLEY-HORN AND ASSOCIATES, INC.  
 8201 PETERS ROAD, SUITE 2200, PLANTATION, FL 33324  
 PHONE: 954-535-5100 FAX: 954-739-2247  
 WWW.KIMLEY-HORN.COM REGISTRY No. 35106

LICENSED PROFESSIONAL	TIFFANY STANTON, P.E.
KHA PROJECT	044533222
DATE	JUN 2024
SCALE	AS SHOWN
DESIGNED BY	TS
DRAWN BY	DC
CHECKED BY	SV
DATE	6/25/2024

# DEMOLITION & EROSION CONTROL IMPROVEMENTS PLAN

LOCH LOMOND NORTH DRAINAGE IMPROVEMENTS PREPARED FOR TOWN OF MIAMI LAKES MIAMI LAKES, FLORIDA

MATCHLINE SEE BOTTOM LEFT FOR CONTINUATION

MATCHLINE SEE SHEET C200.3 FOR CONTINUATION

MATCHLINE SEE SHEET C200.5 FOR CONTINUATION

Plotted By: Cuzpino, Casey - Sheet Set: LOCH LOMOND NORTH DRAINAGE IMPROVEMENTS - Layout: C200.3 DEMOLITION & EROSION CONTROL PLAN - June 25, 2024 - 05:31:04pm - K:\V\civil\044\_Jobs\04453222\_wof20\_loch\_omond\_n.d\CAD\plan\_sheets\C200.1 DEMOLITION & EROSION CONTROL PLAN.dwg  
 This document, together with the concepts and designs presented herein, is intended only for the specific purpose and client for which it was prepared. Reuse of and improper reliance on this document without written authorization and adaptation by Kimley-Horn and Associates, Inc. shall be without liability to Kimley-Horn and Associates, Inc.

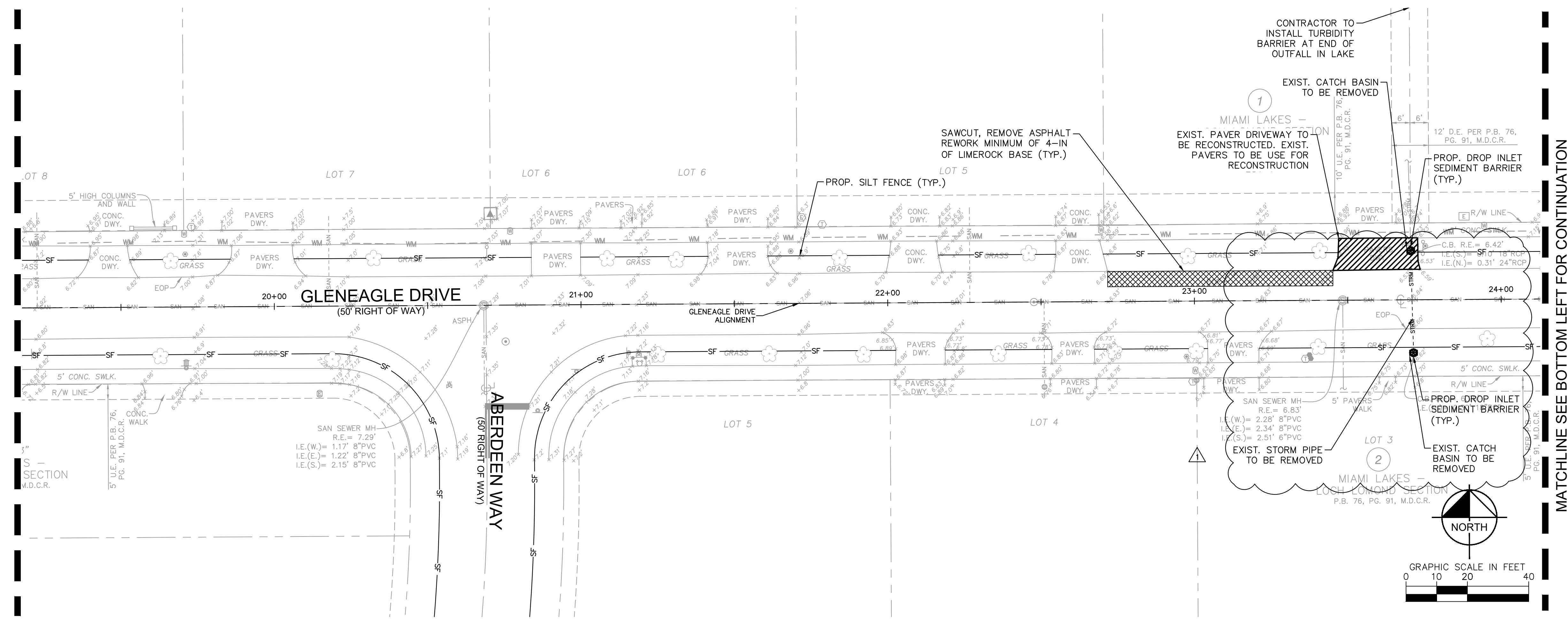

**KEY MAP**

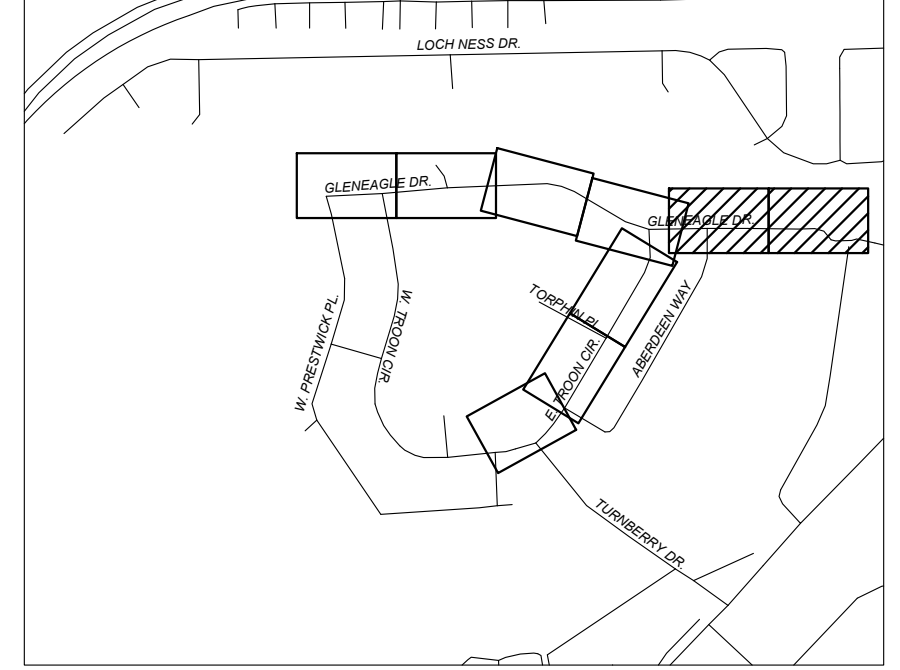

**LEGEND**

- PROPERTY LINE / RIGHT-OF-WAY
- CENTER LINE / ALIGNMENT
- EXISTING SANITARY SEWER PIPE
- EXISTING STORM DRAIN PIPE
- EXISTING WATER MAIN PIPE
- EXISTING STORM CATCH BASIN
- EXISTING STORM MANHOLE
- EXISTING SANITARY SEWER MANHOLE
- EXISTING SIGN
- EXISTING LIGHTPOLE
- EXISTING MAILBOX
- EXISTING VALVE
- EXISTING HYDRANT
- EXISTING GRADE
- PROPOSED INLET SEDIMENT BARRIER
- PROPOSED SILT FENCE
- EXISTING TO BE REMOVED
- EXISTING LIMEROCK BASE TO BE REWORKED
- EXISTING ASPHALT TO BE MILLED & RESURFACED

**NOTES**

1. ALL AREAS DAMAGED BY THE CONTRACTOR, INCLUDING BUT NOT LIMITED TO PAVEMENT MARKINGS, ASPHALT, SWALE, SIDEWALK, AND DRIVEWAYS, SHALL BE RESTORED, AT THE CONTRACTOR'S EXPENSE, TO ORIGINAL CONDITION. SAW CUTTING OF THE EXISTING SIDEWALK SHALL BE MADE ONLY AT THE NEAREST FLAG JOINTS.
2. NO EXISTING TREES SHALL BE REMOVED UNLESS OTHERWISE SPECIFIED.
3. SHOULD ANY EXISTING TREE BE REQUIRED TO BE REMOVED OR RELOCATED BASED ON PROPOSED WORK, CONTRACTOR TO COORDINATE MODIFIED WORK WITH ENGINEER. SHOULD TREE REMOVAL/RELOCATION BE REQUIRED, CONTRACTOR TO OBTAIN ALL REQUIRED PERMITS.
4. ALL ASPHALT TO BE REMOVED SHALL BE SAW CUT ADJACENT TO REMAINING IMPROVEMENTS.
5. CONTRACTOR TO MAINTAIN DRAINAGE FLOW DURING AND AFTER CONSTRUCTION.
6. ALL EXISTING SIGNS IMPACTED BY CONSTRUCTION SHALL BE MODIFIED/RELOCATED AS NECESSARY AT THE CONTRACTOR'S EXPENSE.
7. ALL TREES ARE TO BE PROTECTED AT ALL TIMES DURING CONSTRUCTION.

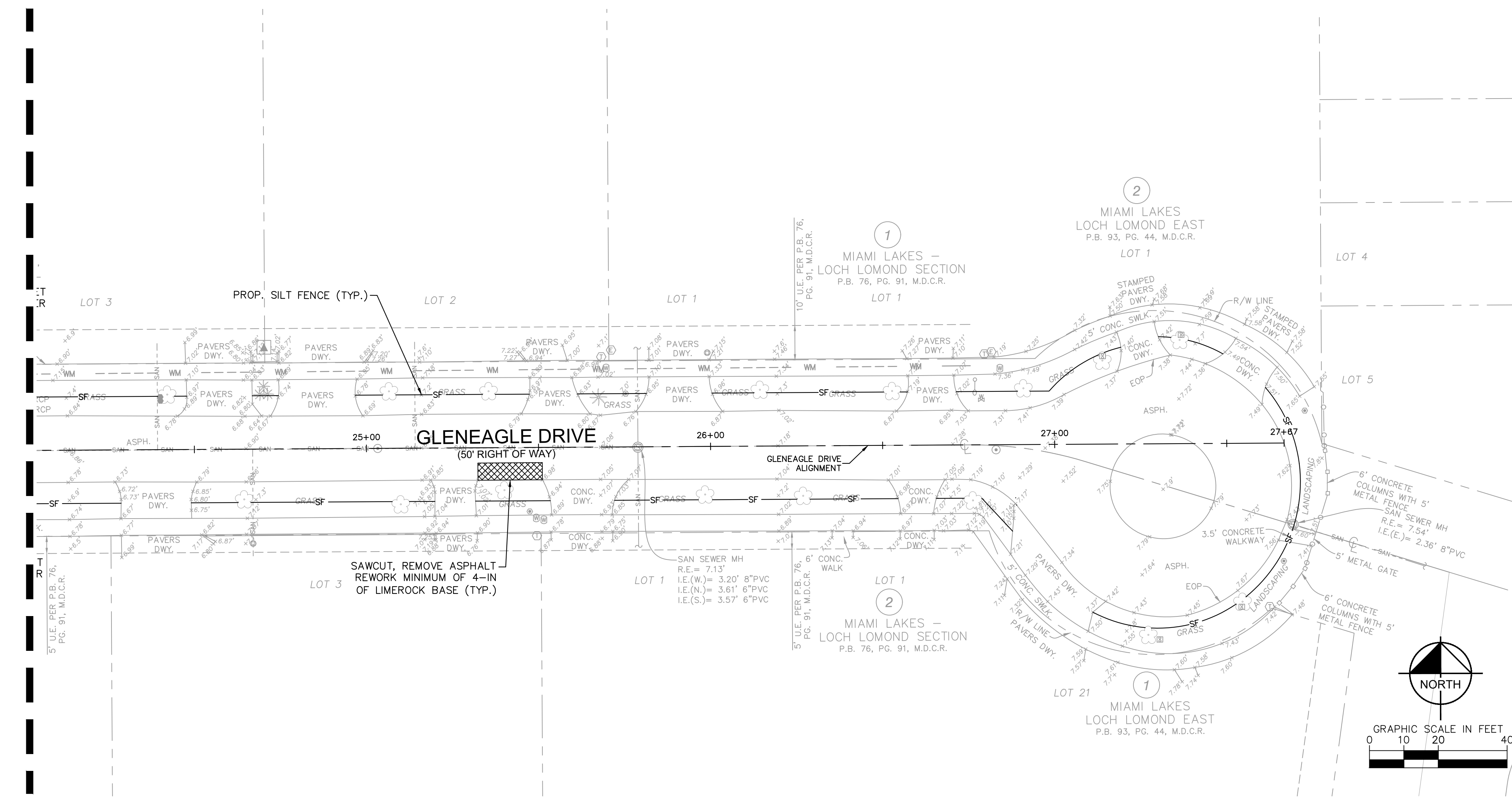

No.	REVISIONS	DATE	BY
1	DEMIG. & PGD UPDATES	6/25/2024	CC

**Kimley»Horn**  
 © 2024 KIMLEY-HORN AND ASSOCIATES, INC.  
 8201 PETERS ROAD, SUITE 2200, PLANTATION, FL 33324  
 PHONE: 954-535-5100 FAX: 954-739-2247  
 WWW.KIMLEY-HORN.COM  
 REGISTRY No. 35106

LICENSED PROFESSIONAL	TIFFANY STANTON, P.E.
KHA PROJECT	04453222
DATE	JUN 2024
SCALE	AS SHOWN
DESIGNED BY	TS
DRAWN BY	DC
CHECKED BY	SV
DATE	6/25/2024

**DEMOLITION & EROSION CONTROL PLAN**

**LOCH LOMOND NORTH DRAINAGE IMPROVEMENTS**  
 PREPARED FOR  
**TOWN OF MIAMI LAKES**  
 MIAMI LAKES, FLORIDA

Plotted By: C. Grubbs, Casey - Sheet Set: LOCH LOMOND NORTH DRAINAGE IMPROVEMENTS - LOVELL C300.1 PAVING, GRADING AND DRAINAGE PLAN - June 25, 2024 - 05:31:36pm - K:\M\civil\044\jobs\044\3222\work\20\loch\_lomond\_north\03\CAD\Drawings\C300.1\_Paving\_Grading\_and\_Drainage\_Plan.dwg  
 This document, together with the concepts and designs presented herein, is intended only for the specific purpose and client for which it was prepared. Reuse of and improper reliance on this document without written authorization and adaptation by Kimley-Horn and Associates, Inc. shall be without liability to Kimley-Horn and Associates, Inc.

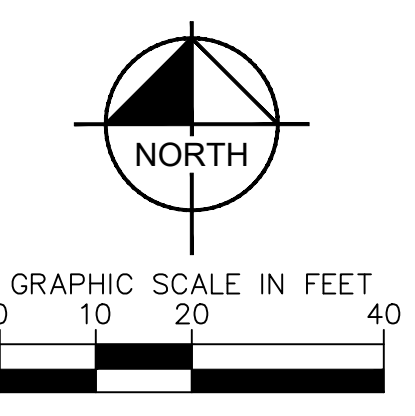
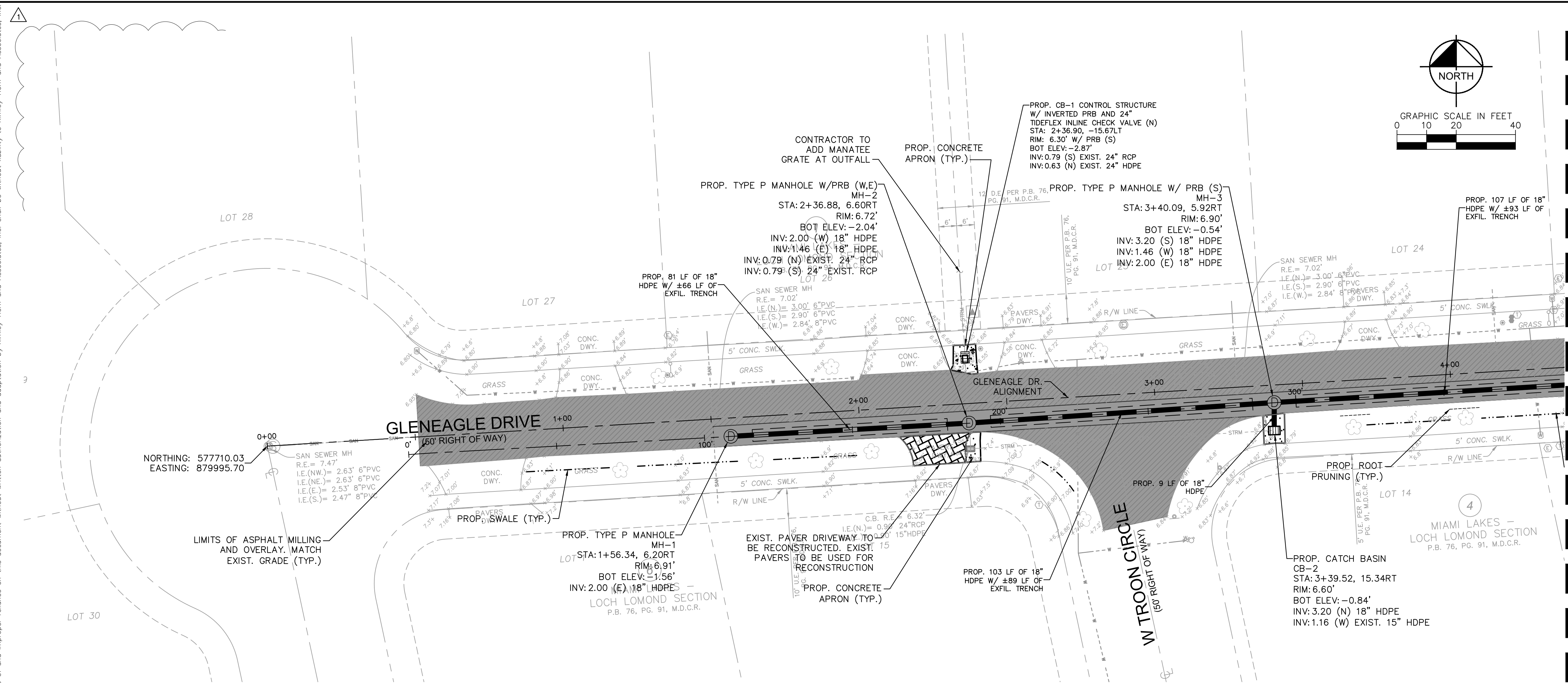

**KEY MAP**

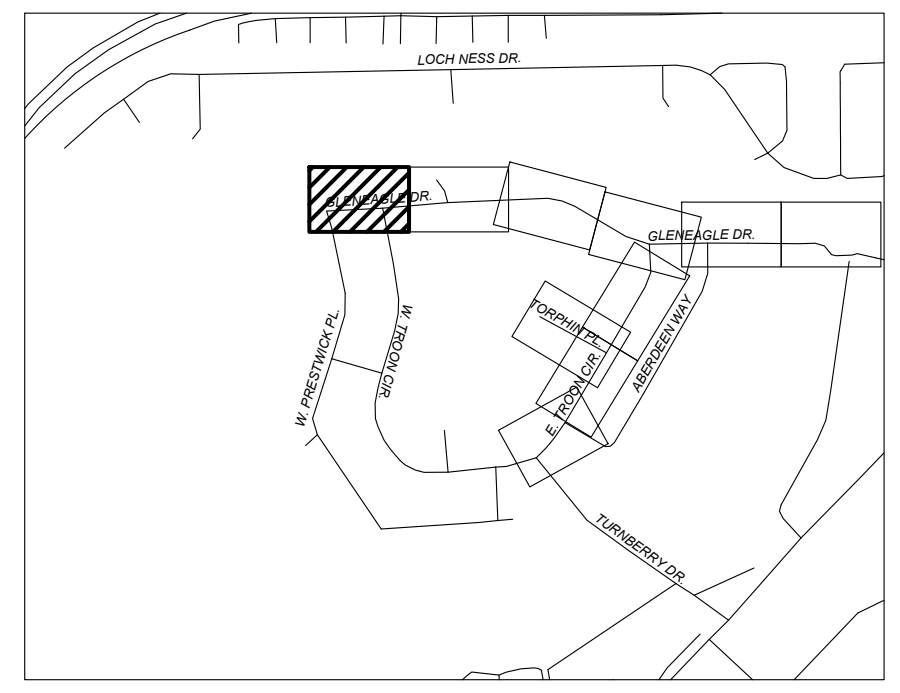

**LEGEND**

- PROPERTY LINE/RIGHT-OF-WAY LINE
- CENTER LINE/ALIGNMENT
- EXISTING SANITARY SEWER PIPE
- EXISTING STORM DRAIN PIPE
- EXISTING WATER MAIN PIPE
- EXISTING OVERHEAD WIRE
- EXISTING STORM CATCH BASIN
- EXISTING STORM MANHOLE
- EXISTING SANITARY SEWER MANHOLE
- EXISTING SIGN
- EXISTING MAILBOX
- EXISTING VALVE
- EXISTING HYDRANT
- EXISTING GRADE
- EXISTING LIGHTPOLE
- PROPOSED ROOT PRUNING
- PROPOSED STORM MANHOLE
- PROPOSED CATCH BASIN
- PROPOSED TRENCH RESTORATION
- PROPOSED MILLING
- PROPOSED PAVEMENT RESTORATION
- PROPOSED ASPHALT PAVEMENT
- PROPOSED CONCRETE
- PROPOSED DRAIN PIPE
- PROPOSED DRAIN PIPE W/ EXFILTRATION TRENCH
- PROPOSED PAVER RECONSTRUCTION
- PROPOSED SWALES

**NOTES**

1. ALL AREAS DAMAGED BY THE CONTRACTOR, INCLUDING BUT NOT LIMITED TO PAVEMENT MARKINGS, ASPHALT, SWALE, SIDEWALK, AND DRIVEWAYS, SHALL BE RESTORED, AT THE CONTRACTOR'S EXPENSE, TO ORIGINAL CONDITION.
2. CONTRACTOR TO MAINTAIN DRAINAGE FLOW DURING AND AFTER CONSTRUCTION.
3. SAW CUTTING OF THE EXISTING SIDEWALK SHALL BE MADE ONLY AT THE NEAREST FLAG JOINTS.
4. NO EXISTING TREES SHALL BE REMOVED UNLESS OTHERWISE SPECIFIED.
5. SHOULD ANY EXISTING TREE BE REQUIRED TO BE REMOVED OR RELOCATED BASED ON PROPOSED WORK, CONTRACTOR TO COORDINATE MODIFIED WORK WITH ENGINEER. SHOULD TREE REMOVAL/RELOCATION BE REQUIRED, CONTRACTOR TO OBTAIN ALL REQUIRED PERMITS.
6. ALL EXISTING MAILBOXES IMPACTED BY CONSTRUCTION SHALL BE MODIFIED/RELOCATED AS NECESSARY AT THE CONTRACTOR'S EXPENSE.
7. ALL SIDEWALKS TO BE 4" THICK, EXCEPT THOSE TRAVERSING DRIVEWAYS SHALL BE 6" THICK, AS PER SIDEWALK DETAIL.
8. PROPOSED SIDEWALK SLOPE SHALL NOT EXCEED MAXIMUM CROSS SLOPE OF 2% AND LONGITUDINAL SLOPE OF 5%.
9. ALL SIDEWALK RAMPS AND DETECTABLE WARNINGS TO MEET FDOT STANDARDS.
10. ALL ASPHALT TO BE REMOVED SHALL BE SAW CUT ADJACENT TO REMAINING IMPROVEMENTS.
11. UTILITIES CROSSING THROUGH EXFILTRATION TRENCH TO BE SLEEVED UNLESS CAST IRON OR DUCTILE IRON SANITARY SEWER, OR CAST IRON, DUCTILE AND STEEL WATER MAIN.
12. EXISTING PIPES TO REMAIN NEED TO BE DESILTED.
13. EXISTING CATCH BASINS AND MANHOLES TO REMAIN TO BE SEALED.

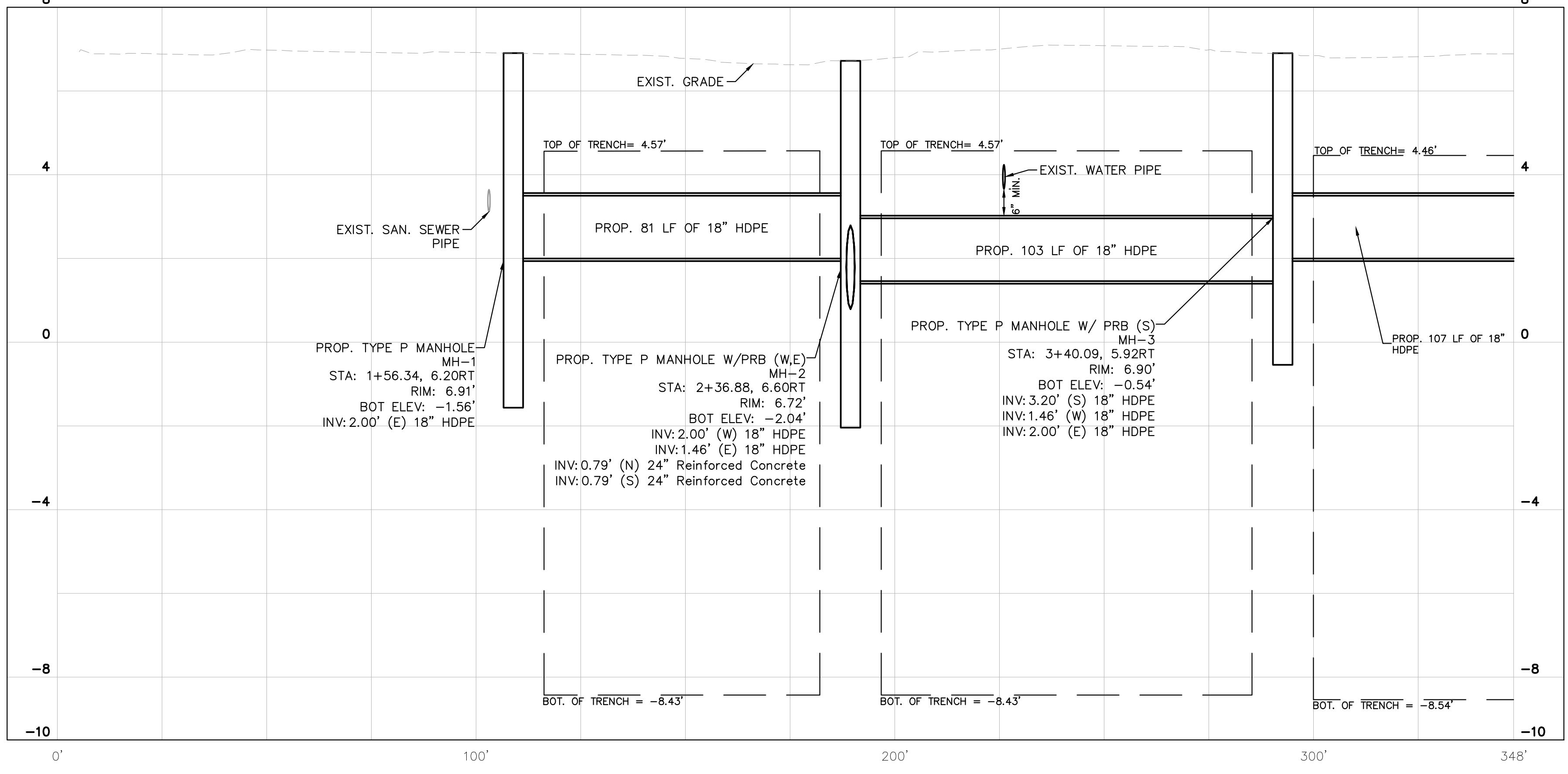

MATCHLINE SEE SHEET C300.2 FOR CONTINUATION

<b>Kimley»Horn</b>		<small>© 2024 KIMLEY-HORN AND ASSOCIATES, INC.        8201 PETERS ROAD, SUITE 2200, PLANTATION, FL 33324        PHONE: 954-535-5100 FAX: 954-739-2247        WWW.KIMLEY-HORN.COM REGISTRY No. 35106</small>	
KHA PROJECT 04453222	DATE JUN 2024	LICENSED PROFESSIONAL TIFFANY STANTON, P.E.	FLORIDA LICENSE NUMBER 85268
SCALE AS SHOWN	DESIGNED BY TS	DRAWN BY DC	CHECKED BY SV
<b>PAVING, GRADING AND DRAINAGE PLAN</b>		DATE: 6/25/2024	
<b>LOCH LOMOND NORTH DRAINAGE IMPROVEMENTS</b>		FLORIDA	
PREPARED FOR <b>TOWN OF MIAMI LAKES</b>		MIAMI LAKES	
SHEET NUMBER <b>C300.1</b>		REVISIONS 1 DEMO & PGD UPDATES 6/25/2024 CC	

Plotted By: C. Cassey - Sheet Set: LOCH LOMOND NORTH DRAINAGE IMPROVEMENTS - Layout: C300.2 PAVING, GRADING AND DRAINAGE PLAN - June 25, 2024 - 05:31:46pm - K:\V\sub\044\Jobs\044\3222\wp20\loch\_lomond\_n\CAD\plan\sheet\c300.2\_paving\_gradation\_and\_drainage\_plan.dwg  
 This document, together with the concepts and designs presented herein, is intended only for the specific purpose and client for which it was prepared. Reuse of and improper reliance on this document without written authorization and adaptation by Kimley-Horn and Associates, Inc. shall be without liability to Kimley-Horn and Associates, Inc.

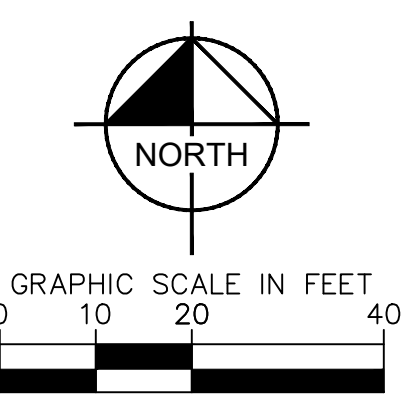
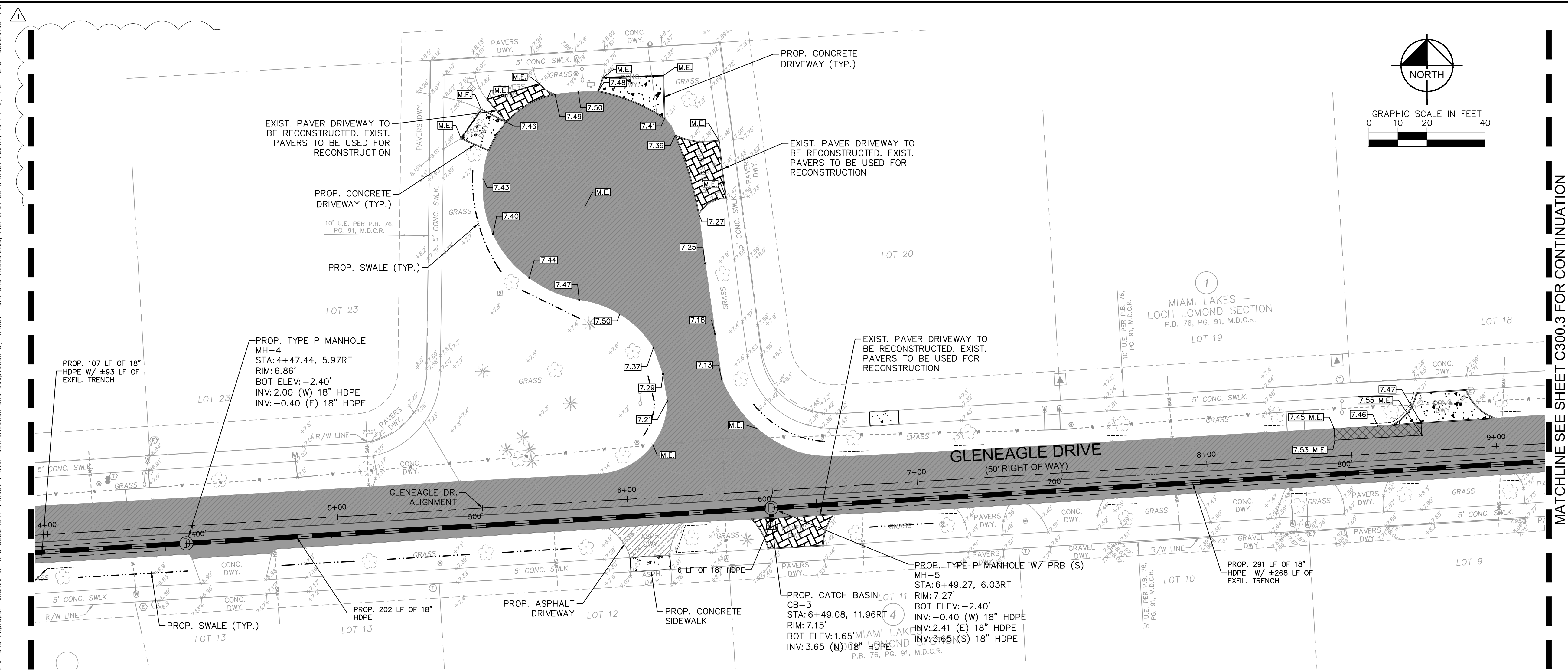

**KEY MAP**

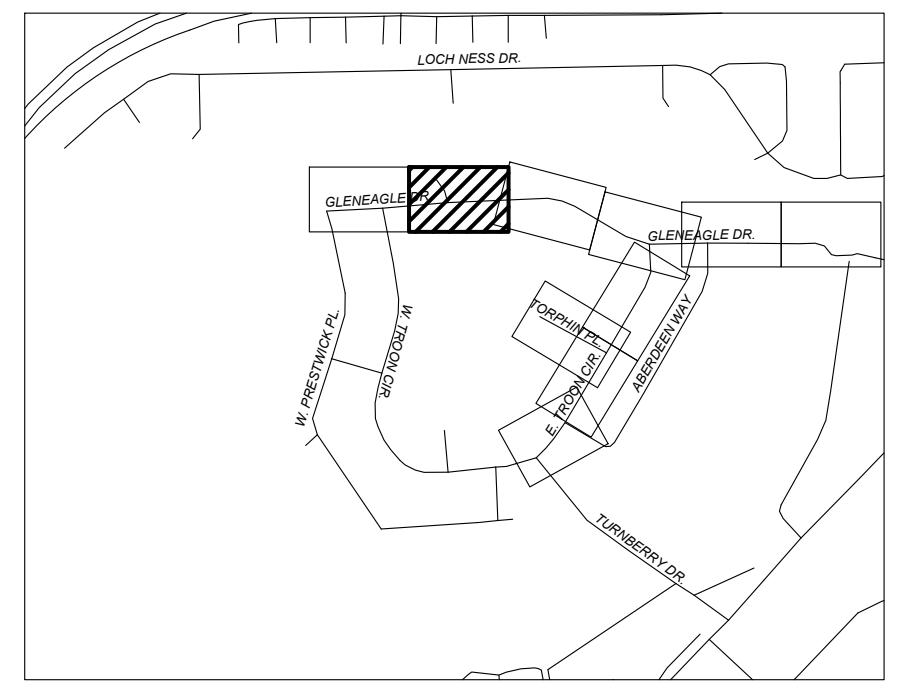

**LEGEND**

- PROPERTY LINE/RIGHT-OF-WAY LINE
- CENTER LINE/ALIGNMENT
- EXISTING SANITARY SEWER PIPE
- EXISTING STORM DRAIN PIPE
- EXISTING WATER MAIN PIPE
- EXISTING OVERHEAD WIRE
- EXISTING STORM CATCH BASIN
- EXISTING STORM MANHOLE
- EXISTING SANITARY SEWER MANHOLE
- EXISTING SIGN
- EXISTING MAILBOX
- EXISTING VALVE
- EXISTING HYDRANT
- EXISTING GRADE
- EXISTING LIGHTPOLE
- PROPOSED ROOT PRUNING
- PROPOSED STORM MANHOLE
- PROPOSED CATCH BASIN
- PROPOSED TRENCH RESTORATION
- PROPOSED MILLING
- PROPOSED PAVEMENT RESTORATION
- PROPOSED ASPHALT PAVEMENT
- PROPOSED CONCRETE
- PROPOSED DRAIN PIPE
- PROPOSED DRAIN PIPE W/ EXFILTRATION TRENCH
- PROPOSED PAVER RECONSTRUCTION
- PROPOSED SWALES

**NOTES**

1. ALL AREAS DAMAGED BY THE CONTRACTOR, INCLUDING BUT NOT LIMITED TO PAVEMENT MARKINGS, ASPHALT, SWALE, SIDEWALK, AND DRIVEWAYS, SHALL BE RESTORED, AT THE CONTRACTOR'S EXPENSE, TO ORIGINAL CONDITION. CONTRACTOR TO MAINTAIN DRAINAGE FLOW DURING AND AFTER CONSTRUCTION.
2. SAW CUTTING OF THE EXISTING SIDEWALK SHALL BE MADE ONLY AT THE NEAREST FLAG JOINTS.
3. NO EXISTING TREES SHALL BE REMOVED UNLESS OTHERWISE SPECIFIED.
4. SHOULD ANY EXISTING TREE BE REQUIRED TO BE REMOVED OR RELOCATED BASED ON PROPOSED WORK, CONTRACTOR TO COORDINATE MODIFIED WORK WITH ENGINEER. SHOULD TREE REMOVAL/RELOCATION BE REQUIRED, CONTRACTOR TO OBTAIN ALL REQUIRED PERMITS.
5. ALL EXISTING MAILBOXES IMPACTED BY CONSTRUCTION SHALL BE MODIFIED/RELOCATED AS NECESSARY AT THE CONTRACTOR'S EXPENSE.
6. ALL SIDEWALKS TO BE 4" THICK, EXCEPT THOSE TRAVERSING DRIVEWAYS SHALL BE 6" THICK, AS PER SIDEWALK DETAIL.
7. PROPOSED SIDEWALK SLOPE SHALL NOT EXCEED MAXIMUM CROSS SLOPE OF 2% AND LONGITUDINAL SLOPE OF 5%.
8. ALL SIDEWALK RAMPS AND DETECTABLE WARNINGS TO MEET FDOT STANDARDS.
9. ALL ASPHALT TO BE REMOVED SHALL BE SAW CUT ADJACENT TO REMAINING IMPROVEMENTS.
10. UTILITIES CROSSING THROUGH EXFILTRATION TRENCH TO BE SLEEVED UNLESS CAST IRON OR DUCTILE IRON SANITARY SEWER, OR CAST IRON, DUCTILE AND STEEL WATER MAIN.
11. EXISTING PIPES TO REMAIN NEED TO BE DESILTED.
12. EXISTING CATCH BASINS AND MANHOLES TO REMAIN TO BE SEALED.

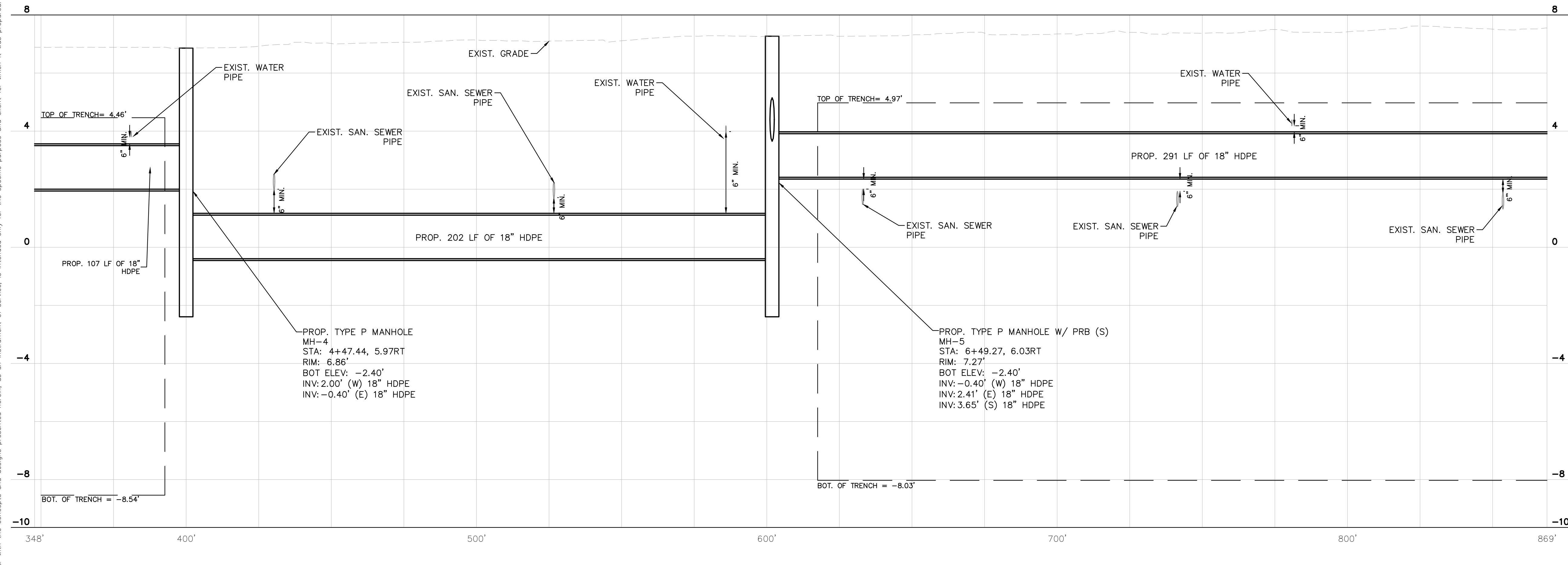

GLENEAGLE DRIVE STORM PROFILE  
 348' TO 869'  
 1"=20' (HORZ.)  
 1"=2' (VERT)

MATCHLINE SEE SHEET C300.3 FOR CONTINUATION

<b>Kimley»Horn</b>		LICENSED PROFESSIONAL TIFFANY STANTON, P.E. DATE: JUN 2024 SCALE: AS SHOWN DESIGNED BY: TS DRAWN BY: DC CHECKED BY: SV DATE: 6/25/2024
<b>PAVING, GRADING          AND DRAINAGE PLAN</b>		PROJECT NO: 044-53222 SHEET NO: C300.2 TOWN OF MIAMI LAKES FLORIDA
LOCH LOMOND NORTH DRAINAGE IMPROVEMENTS PREPARED FOR TOWN OF MIAMI LAKES MIAMI LAKES, FLORIDA		SHEET NUMBER <b>C300.2</b>
DEMO. & PGD UPDATES 1 No.	REVISIONS 6/25/2024 CC	DATE BY





PLOTTED BY: C:\Users\jcs351\OneDrive\Desktop\LOCH LOMOND NORTH DRAINAGE IMPROVEMENTS - Layout\C300.5 PAVING, GRADING AND DRAINAGE PLAN - June 25, 2024 - 05:32:12pm - K:\V\044\Jobs\04453222\work2\loch\_lomond\_north.dwg - User: jcs351 - Plot Date: 6/25/2024 - 05:32:12pm - This document, together with the concepts and designs presented herein, is intended only for the specific purpose and client for which it was prepared. Reuse of and improper reliance on this document without written authorization and adaptation by Kimley-Horn and Associates, Inc. shall be without liability to Kimley-Horn and Associates, Inc.

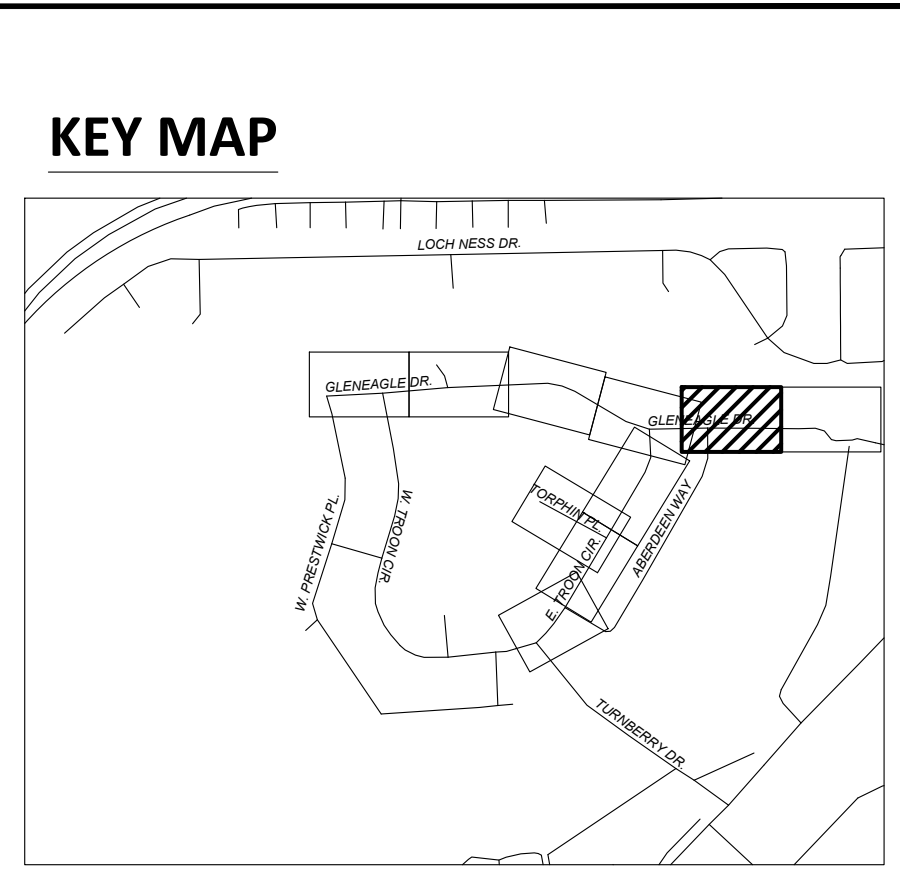
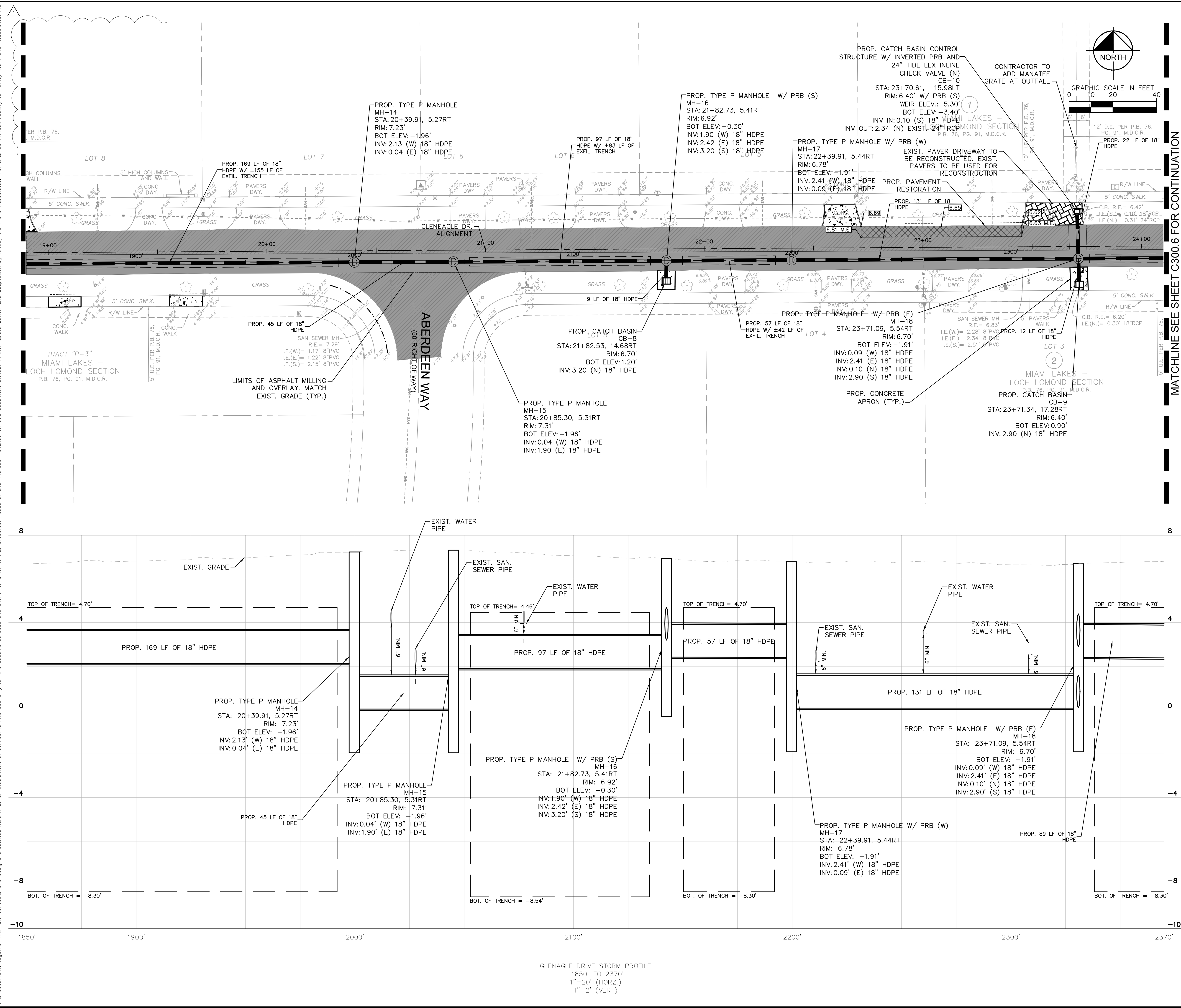

**LEGEND**

	PROPERTY LINE/RIGHT-OF-WAY LINE
	CENTER LINE/ALIGNMENT
	EXISTING SANITARY SEWER PIPE
	EXISTING STORM DRAIN PIPE
	EXISTING WATER MAIN PIPE
	EXISTING OVERHEAD WIRE
	EXISTING STORM CATCH BASIN
	EXISTING STORM MANHOLE
	EXISTING SANITARY SEWER MANHOLE
	EXISTING SIGN
	EXISTING MAILBOX
	EXISTING VALVE
	EXISTING HYDRANT
	EXISTING GRADE
	EXISTING LIGHTPOLE
	PROPOSED ROOT PRUNING
	PROPOSED STORM MANHOLE
	PROPOSED CATCH BASIN
	PROPOSED TRENCH RESTORATION
	PROPOSED MILLING
	PROPOSED PAVEMENT RESTORATION
	PROPOSED ASPHALT PAVEMENT
	PROPOSED CONCRETE
	PROPOSED DRAIN PIPE
	PROPOSED DRAIN PIPE W/ EXFILTRATION TRENCH
	PROPOSED PAVER RECONSTRUCTION
	PROPOSED SWALES

- NOTES**
- ALL AREAS DAMAGED BY THE CONTRACTOR, INCLUDING BUT NOT LIMITED TO PAVEMENT MARKINGS, ASPHALT, SWALE, SIDEWALK, AND DRIVEWAYS, SHALL BE RESTORED, AT THE CONTRACTOR'S EXPENSE, TO ORIGINAL CONDITION, DURING AND AFTER CONSTRUCTION.
  - CONTRACTOR TO MAINTAIN DRAINAGE FLOW DURING AND AFTER CONSTRUCTION.
  - SAW CUTTING OF THE EXISTING SIDEWALK SHALL BE MADE ONLY AT THE NEAREST FLAG JOINTS.
  - NO EXISTING TREES SHALL BE REMOVED UNLESS OTHERWISE SPECIFIED.
  - SHOULD ANY EXISTING TREE BE REQUIRED TO BE REMOVED OR RELOCATED BASED ON PROPOSED WORK, CONTRACTOR TO COORDINATE MODIFIED WORK WITH ENGINEER. SHOULD TREE REMOVAL/RELOCATION BE REQUIRED, CONTRACTOR TO OBTAIN ALL REQUIRED PERMITS. ALL EXISTING MAILBOXES IMPACTED BY CONSTRUCTION SHALL BE MODIFIED/RELOCATED AS NECESSARY AT THE CONTRACTOR'S EXPENSE.
  - ALL EXISTING MAILBOXES IMPACTED BY CONSTRUCTION SHALL BE MODIFIED/RELOCATED AS NECESSARY AT THE CONTRACTOR'S EXPENSE.
  - ALL SIDEWALKS TO BE 4" THICK, EXCEPT THOSE TRAVERSING DRIVEWAYS SHALL BE 6" THICK, AS PER SIDEWALK DETAIL.
  - PROPOSED SIDEWALK SLOPE SHALL NOT EXCEED MAXIMUM CROSS SLOPE OF 2% AND LONGITUDINAL SLOPE OF 5%.
  - ALL SIDEWALK RAMP AND DETECTABLE WARNINGS TO MEET FDOT STANDARDS.
  - ALL ASPHALT TO BE REMOVED SHALL BE SAW CUT ADJACENT TO REMAINING IMPROVEMENTS.
  - UTILITIES CROSSING THROUGH EXFILTRATION TRENCH TO BE SLEEVED UNLESS CAST IRON OR DUCTILE IRON SANITARY SEWER, OR CAST IRON, DUCTILE AND STEEL WATER MAIN.
  - EXISTING PIPES TO REMAIN NEED TO BE DESILTED.
  - EXISTING CATCH BASINS AND MANHOLES TO REMAIN TO BE SEALED.

<b>Kimley»Horn</b>		LICENSED PROFESSIONAL TIFFANY STANTON, P.E. DATE: JUN 2024 SCALE: AS SHOWN DESIGNED BY: TS DRAWN BY: DC CHECKED BY: SV DATE: 6/25/2024
<b>LOCH LOMOND NORTH DRAINAGE IMPROVEMENTS</b> PREPARED FOR <b>TOWN OF MIAMI LAKES</b> MIAMI LAKES, FLORIDA		SHEET NUMBER <b>C300.5</b>
<b>PAVING, GRADING AND DRAINAGE PLAN</b>		DEMO & PGD UPDATES 6/25/2024 DATE











Plotted By: Crispino, Casey - Sheet Set: LOCH LOMOND NORTH DRAINAGE IMPROVEMENTS - Layout: C301.3 PAVING GRADING AND DRAINAGE DETAILS - June 25, 2024 - 09:33:16pm - K:\YU\ch\044 - jobs\044533222 - wj\20 loc\romond n. d\CAD\plan sheets\C301.3 PAVING GRADING AND DRAINAGE DETAILS.dwg  
 This document, together with the concepts and designs presented herein, is intended only for the specific purpose and client for which it was prepared. Reuse of and improper reliance on this document without written authorization and adaptation by Kimley-Horn and Associates, Inc. shall be without liability to Kimley-Horn and Associates, Inc.

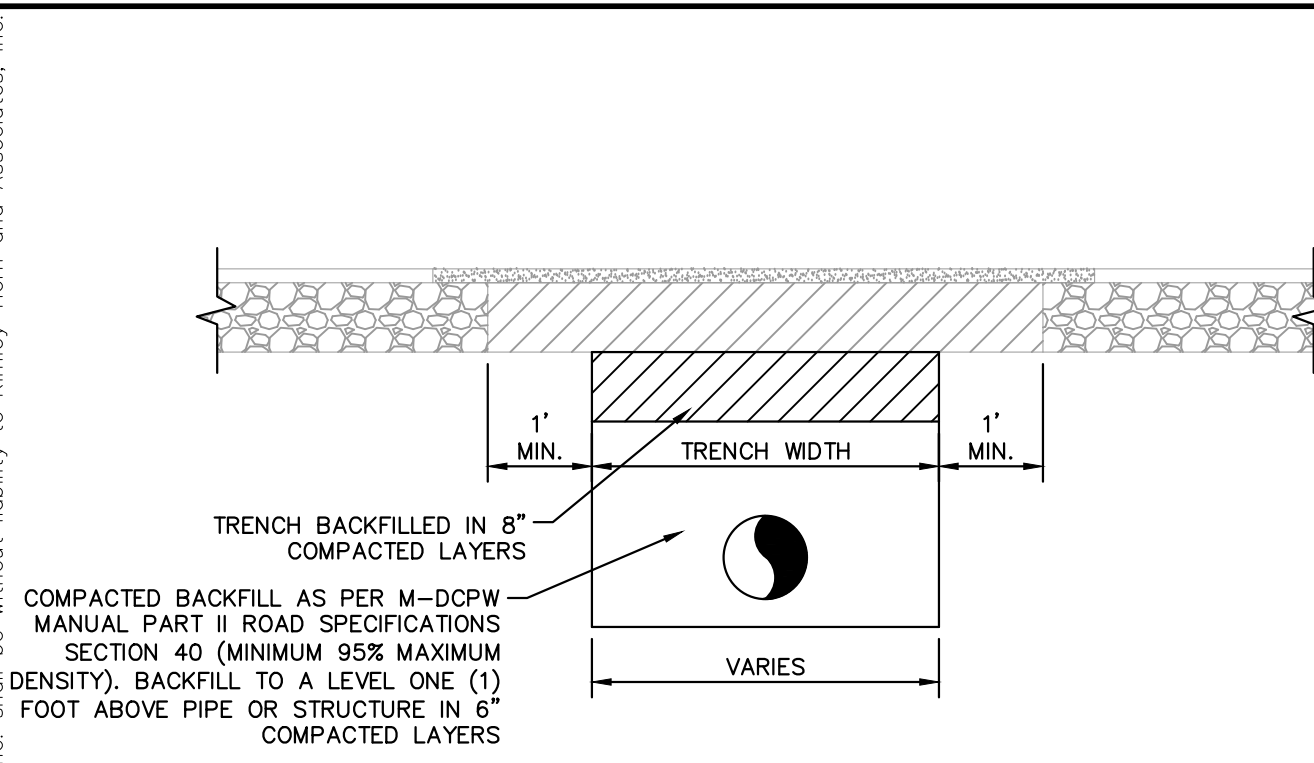

**GENERAL NOTES:**  
 1. BID PRICES FOR PIPE AND/OR FRENCH DRAIN SHALL INCLUDE PAVEMENT RESTORATION TO MATCH EXISTING GRADES. CONTRACTOR SHALL NOT LEAVE MORE THAN 1,000-FEET OF EXPOSED LIMEROCK BASE AT ANY TIME DURING THE TRENCH/PAVEMENT RESTORATION PROCESS.  
 2. WHEN TRENCHING OUTSIDE THE PAVEMENT AREA, ASPHALT AND BASE MATERIAL REFERENCED IN GENERAL NOTES ARE NOT REQUIRED. RESTORE OR REPLACE ALL PUBLIC OR PRIVATE PROPERTY TO A CONDITION AT LEAST EQUAL TO THAT EXISTING IMMEDIATELY PRIOR TO COMMENCEMENT OF CONSTRUCTION. ALL IMPACTED AREAS SHALL BE COMPACTED TO 95% DENSITY IN 6-INCH MAXIMUM LIFTS.

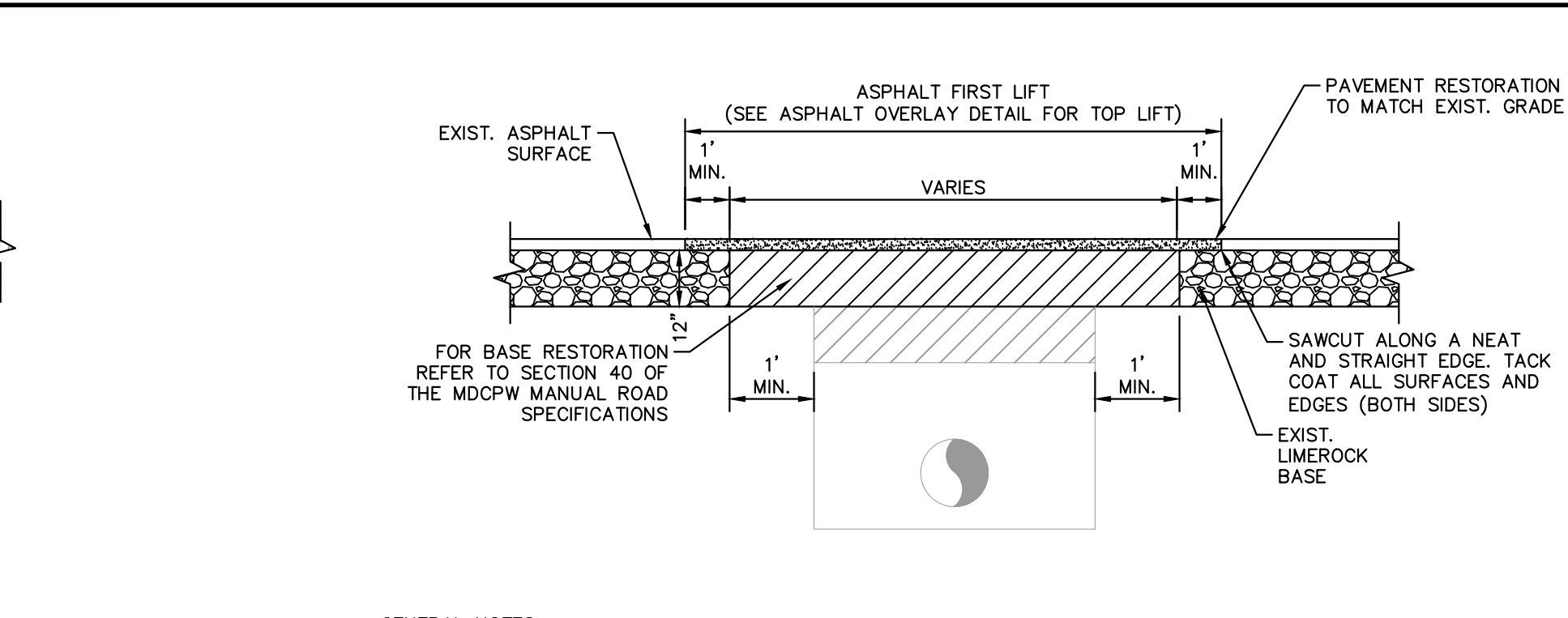

**GENERAL NOTES:**  
 1. ASPHALTIC CONCRETE PAVEMENT JOINTS SHALL BE MECHANICALLY SAWED.  
 2. SURFACE TREATED PAVEMENT JOINTS SHALL BE LAPPED AND FEATHERED. PAVEMENT MATERIAL SHALL BE 2-1/2" TYPE SP-9.5 (FINE MIX) FIRST LIFT. SEE OVERLAY DETAIL FOR TOP LIFT.  
 3. WHEN TRENCHING OUTSIDE THE PAVEMENT AREA, ASPHALT AND BASE MATERIAL REFERENCED IN GENERAL NOTES ARE NOT REQUIRED. RESTORE OR REPLACE ALL PUBLIC OR PRIVATE PROPERTY TO A CONDITION AT LEAST EQUAL TO THAT EXISTING IMMEDIATELY PRIOR TO COMMENCEMENT OF CONSTRUCTION. ALL IMPACTED AREAS SHALL BE COMPACTED TO 95% DENSITY IN 6-INCH MAXIMUM LIFTS.  
 4. PAVEMENT RESTORATION FOR LONGITUDINAL CUTS SHALL INCLUDE FULL LANE WIDTH RESURFACING FOR EACH LANE WITHIN WHICH THE CUT EXTENDS.  
 5. IN SOME CASES IT WILL BE NECESSARY TO OVERLAY MORE THAN ONE (1) LANE WITH ASPHALTIC CONCRETE TO SATISFY PAVEMENT SLOPE.  
 6. BASE MATERIAL SHALL BE PLACED IN 6 INCH MAXIMUM LAYERS AND EACH LAYER THOROUGHLY ROLLED OR TAMPED TO 98% OF MAXIMUM DENSITY, PER AASHTO T-180. BASE MATERIAL SHALL HAVE A MINIMUM LBR OF 100.

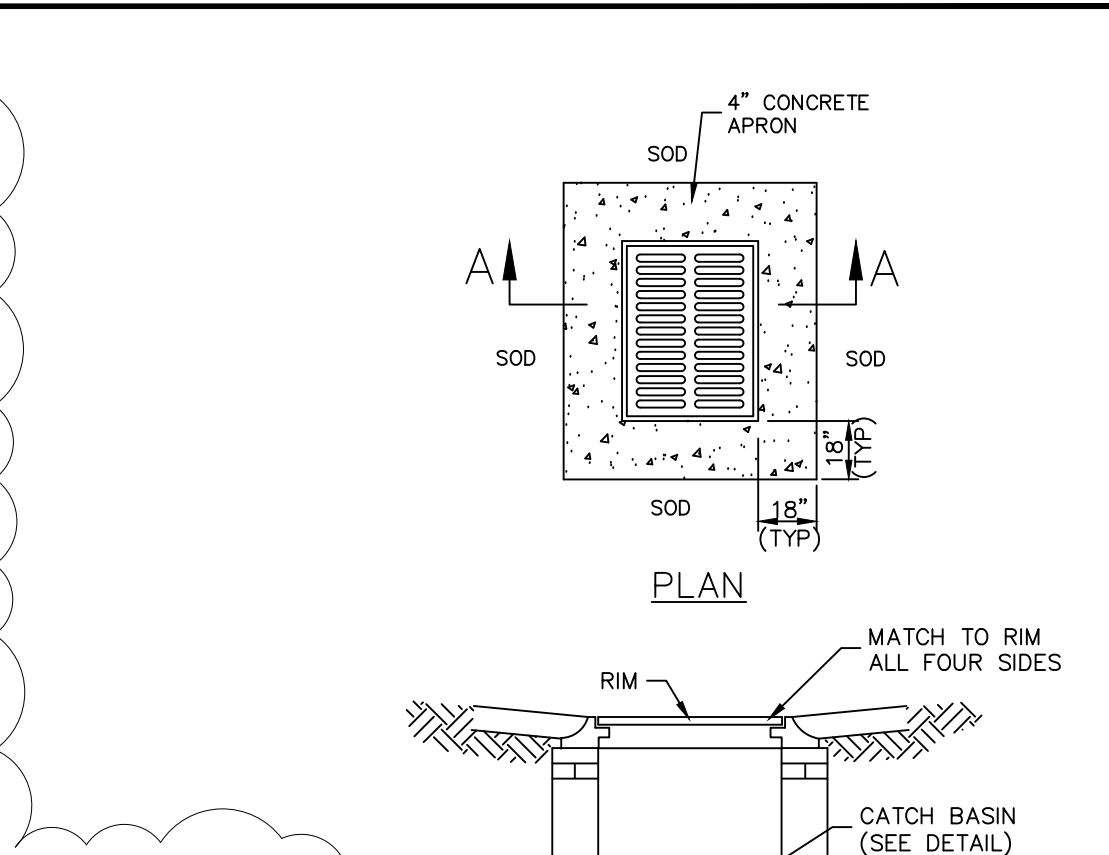
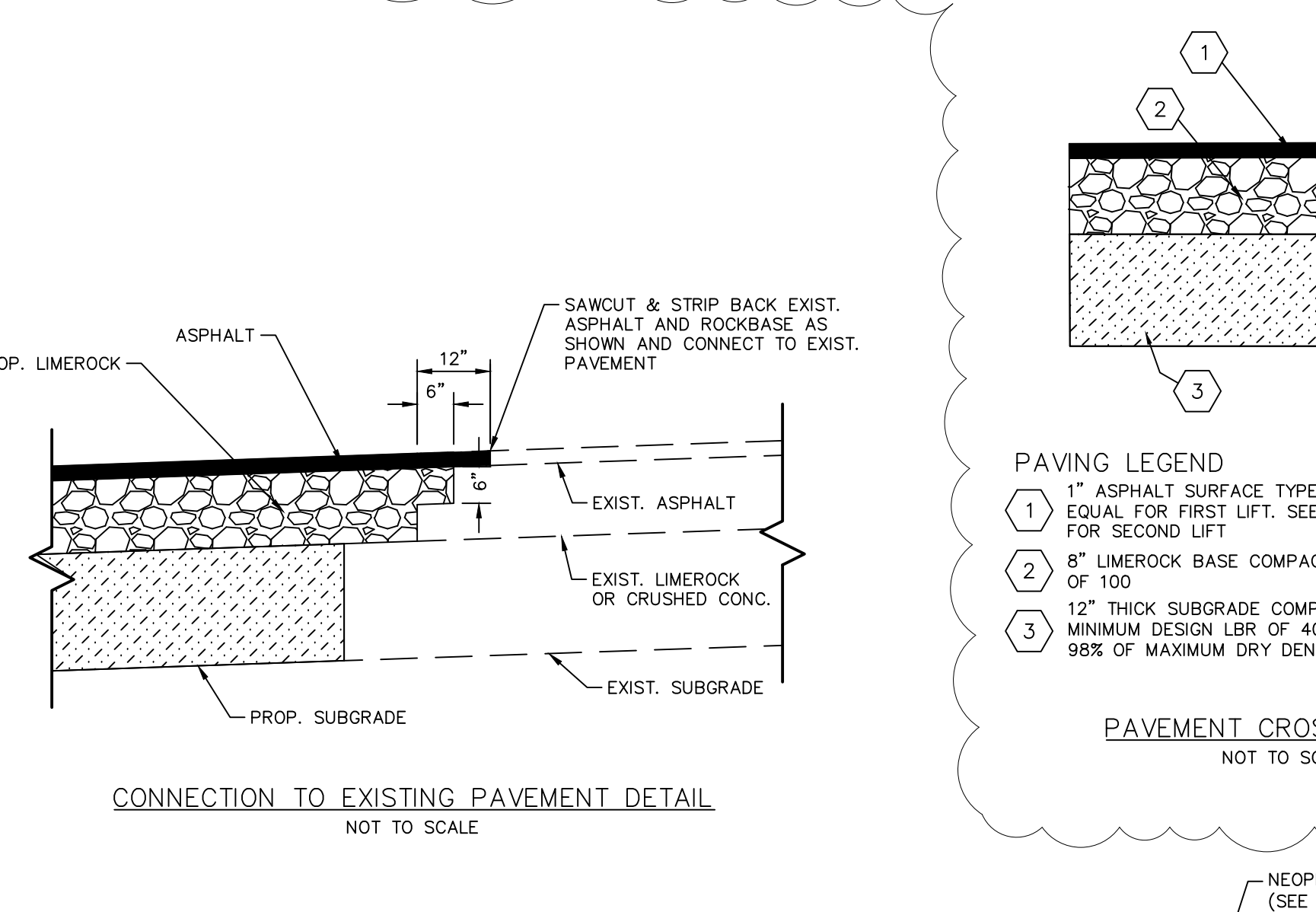
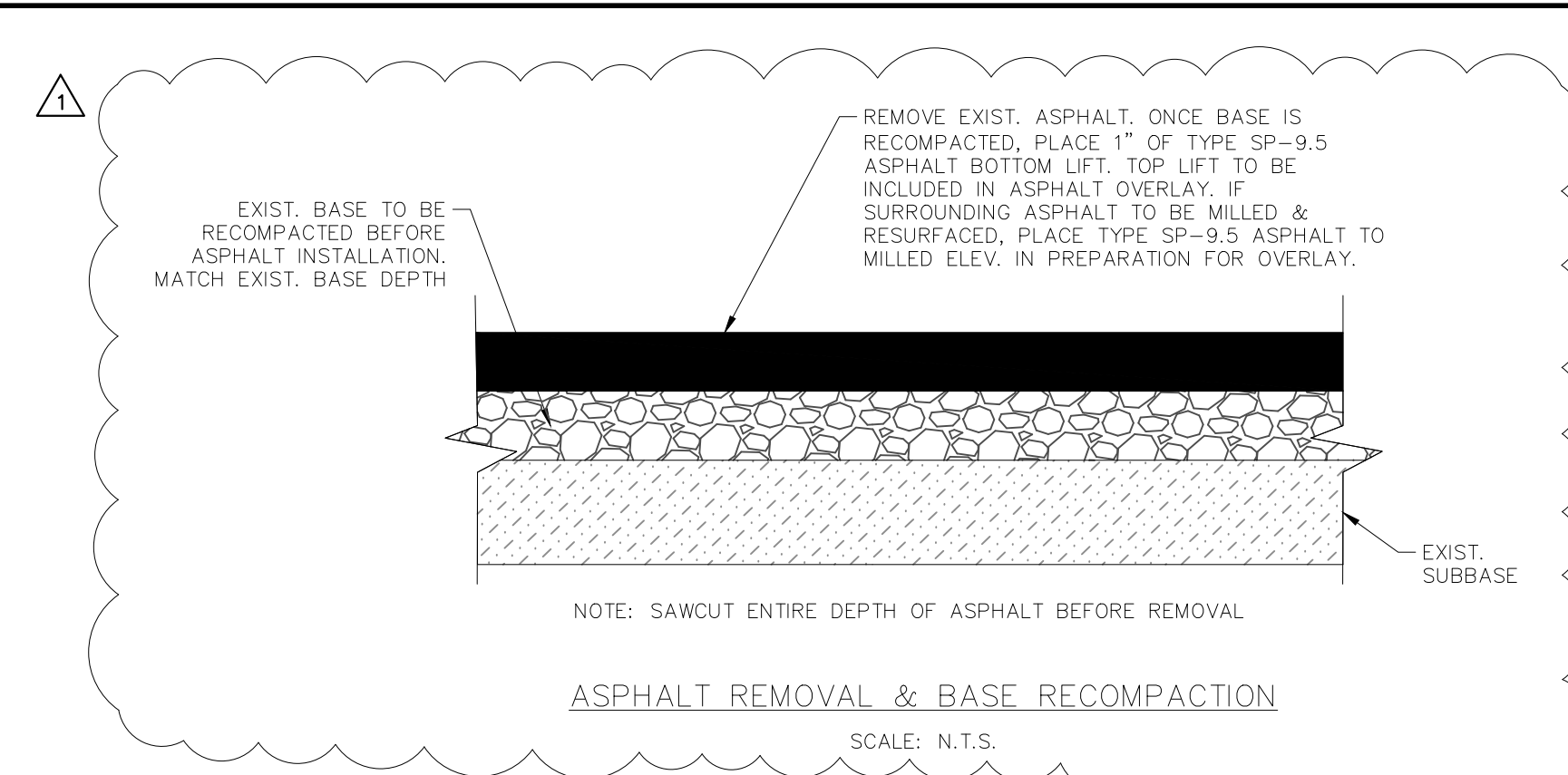
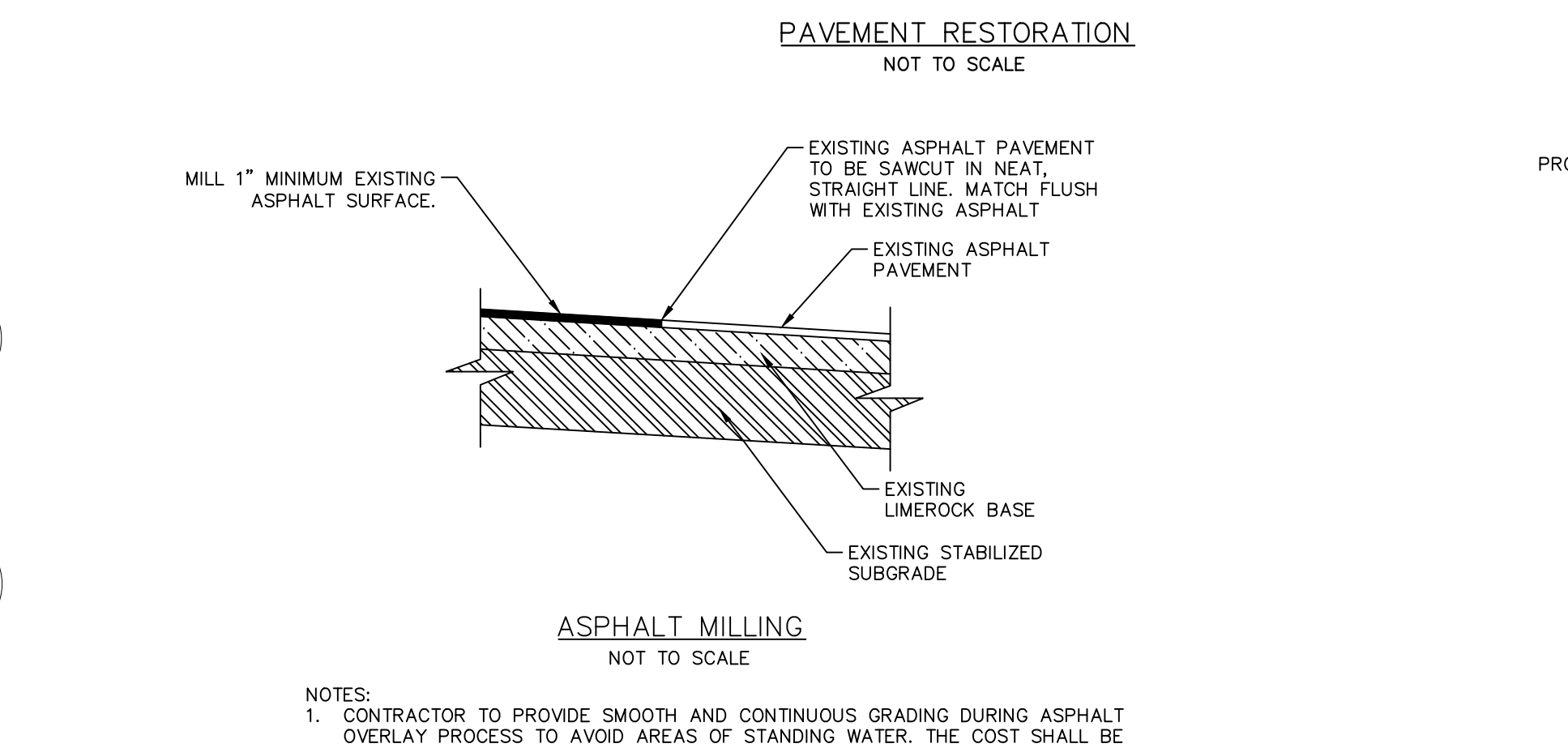
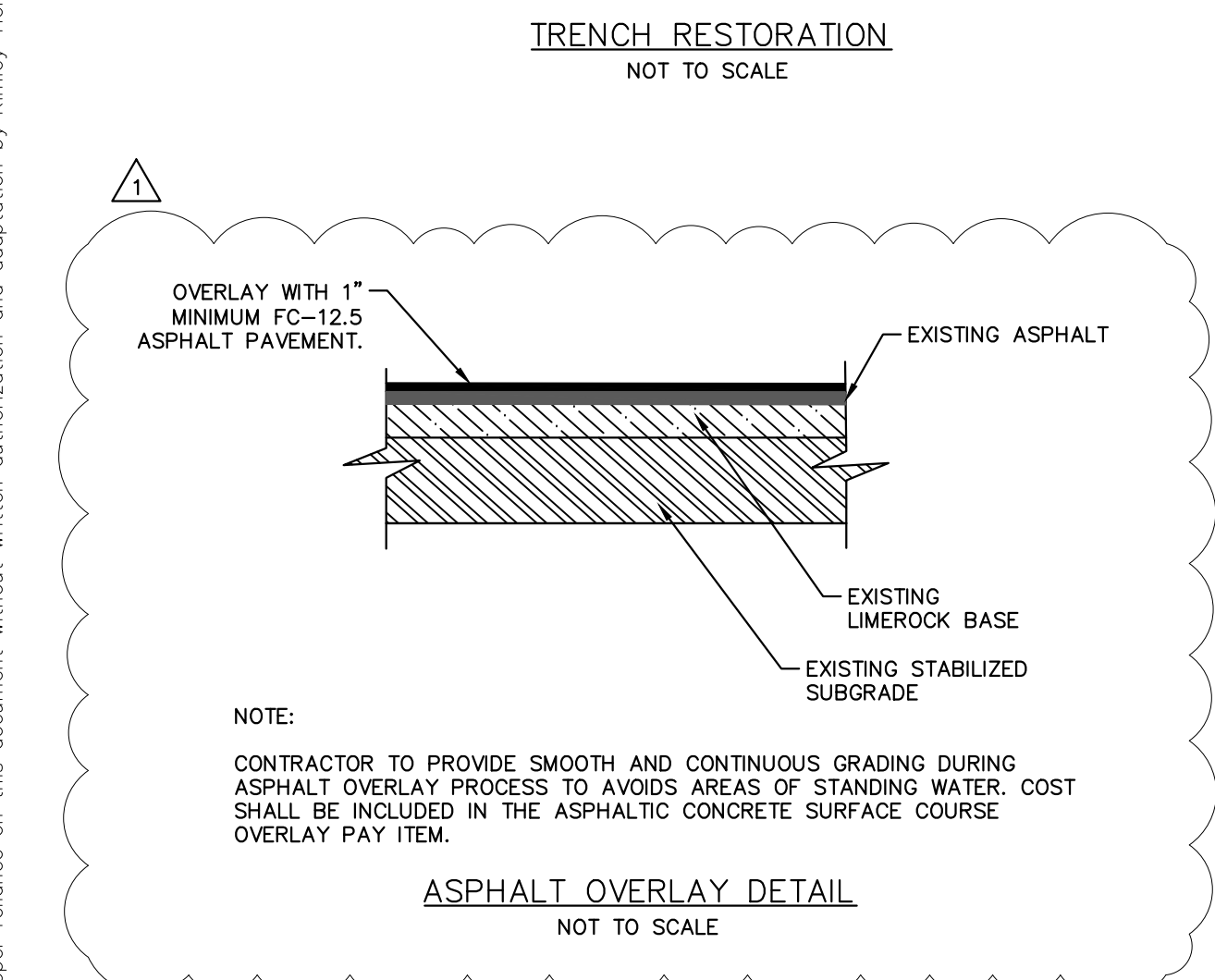

**PAVING LEGEND**  
 1 1" ASPHALT SURFACE TYPE SP-9.5 OR APPROVED EQUAL FOR FIRST LIFT. SEE ASPHALT OVERLAY DETAIL FOR SECOND LIFT  
 2 8" LIMEROCK BASE COMPACTED WITH MINIMUM LBR OF 100  
 3 12" THICK SUBGRADE COMPACTED AND STABILIZED WITH MINIMUM DESIGN LBR OF 40 COMPACTED TO AT LEAST 98% OF MAXIMUM DRY DENSITY (AASHTO T-180)

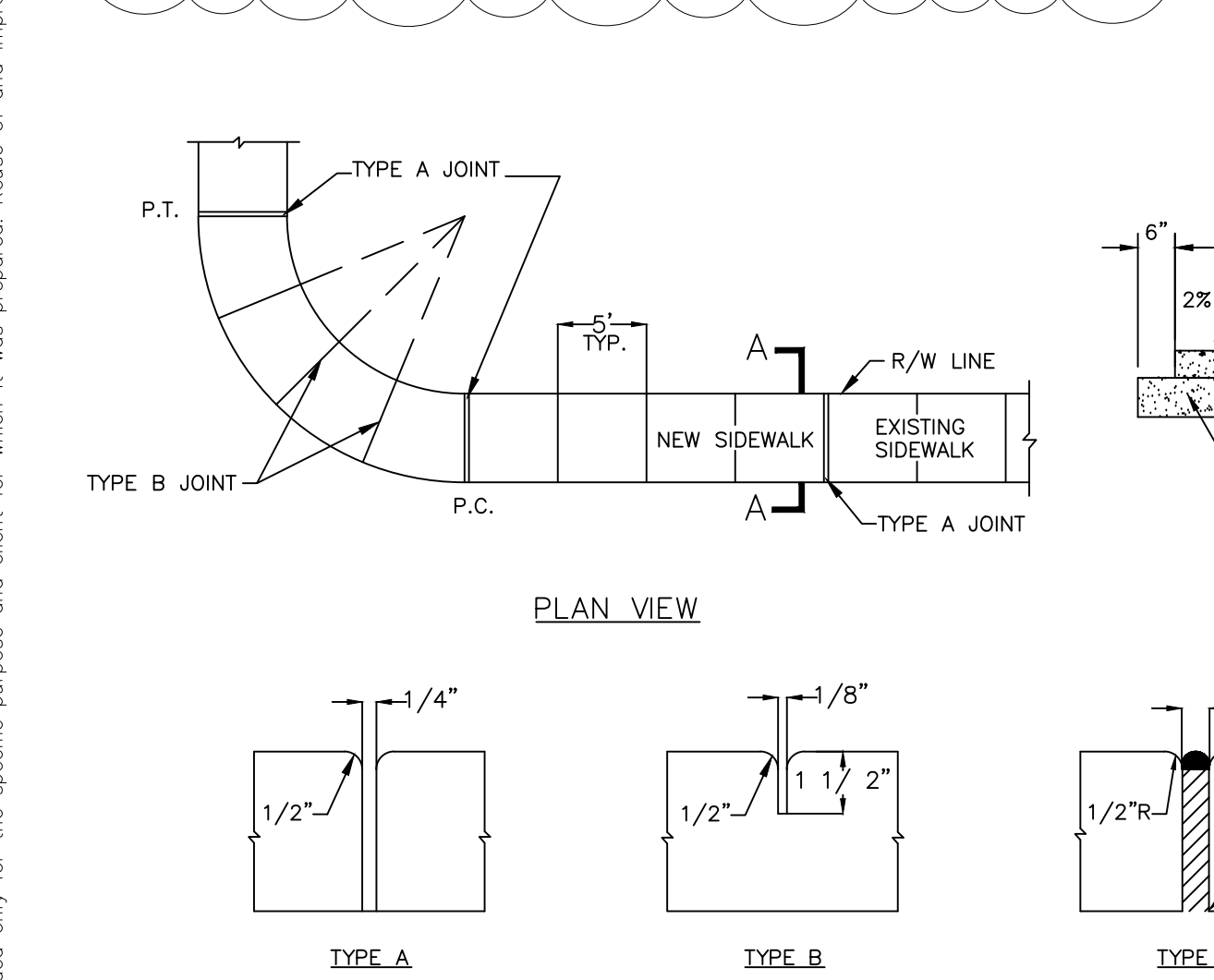
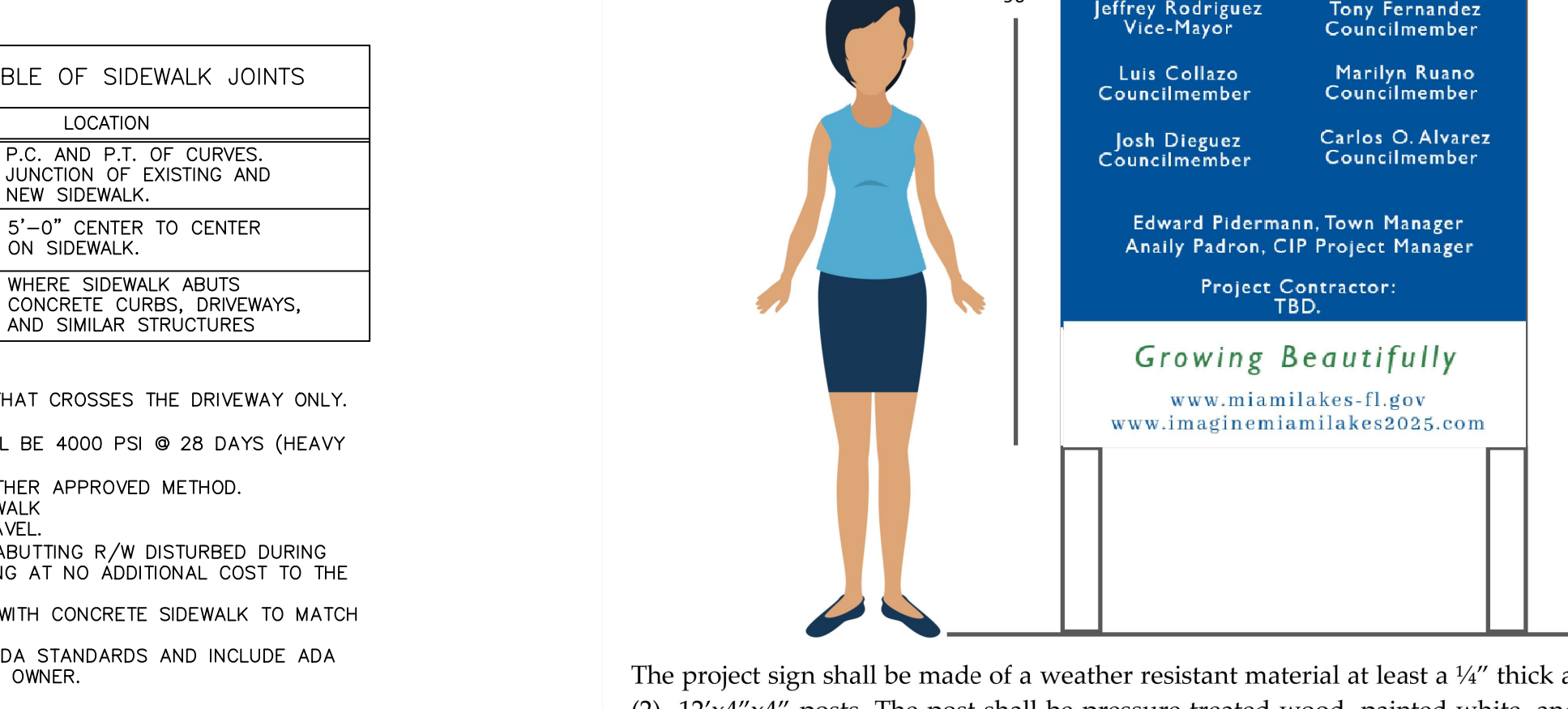
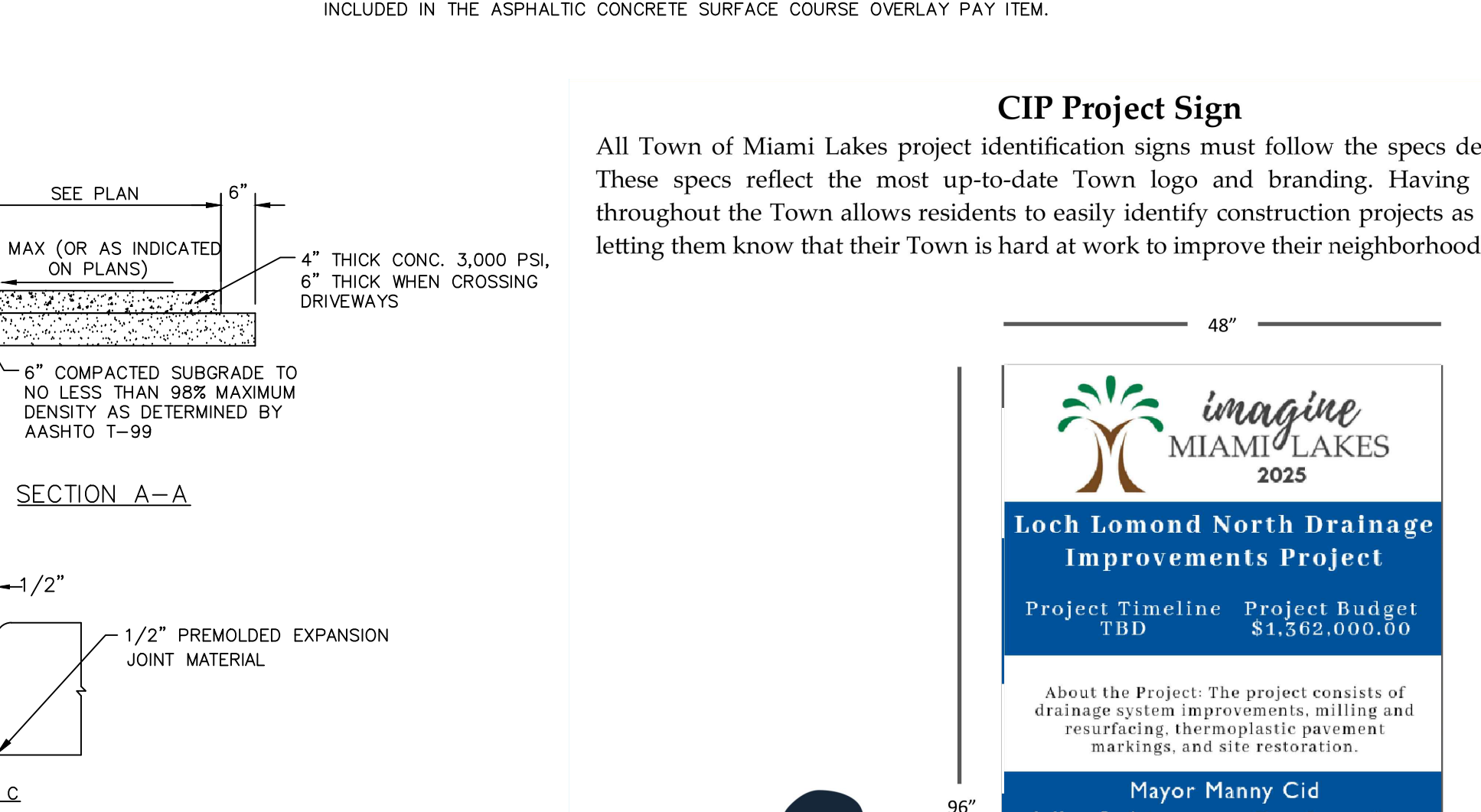

TABLE OF SIDEWALK THICKNESS - T	
LOCATION	T
STANDARD SIDEWALK	4"
AT DRIVEWAYS AND OTHER AREAS	6"

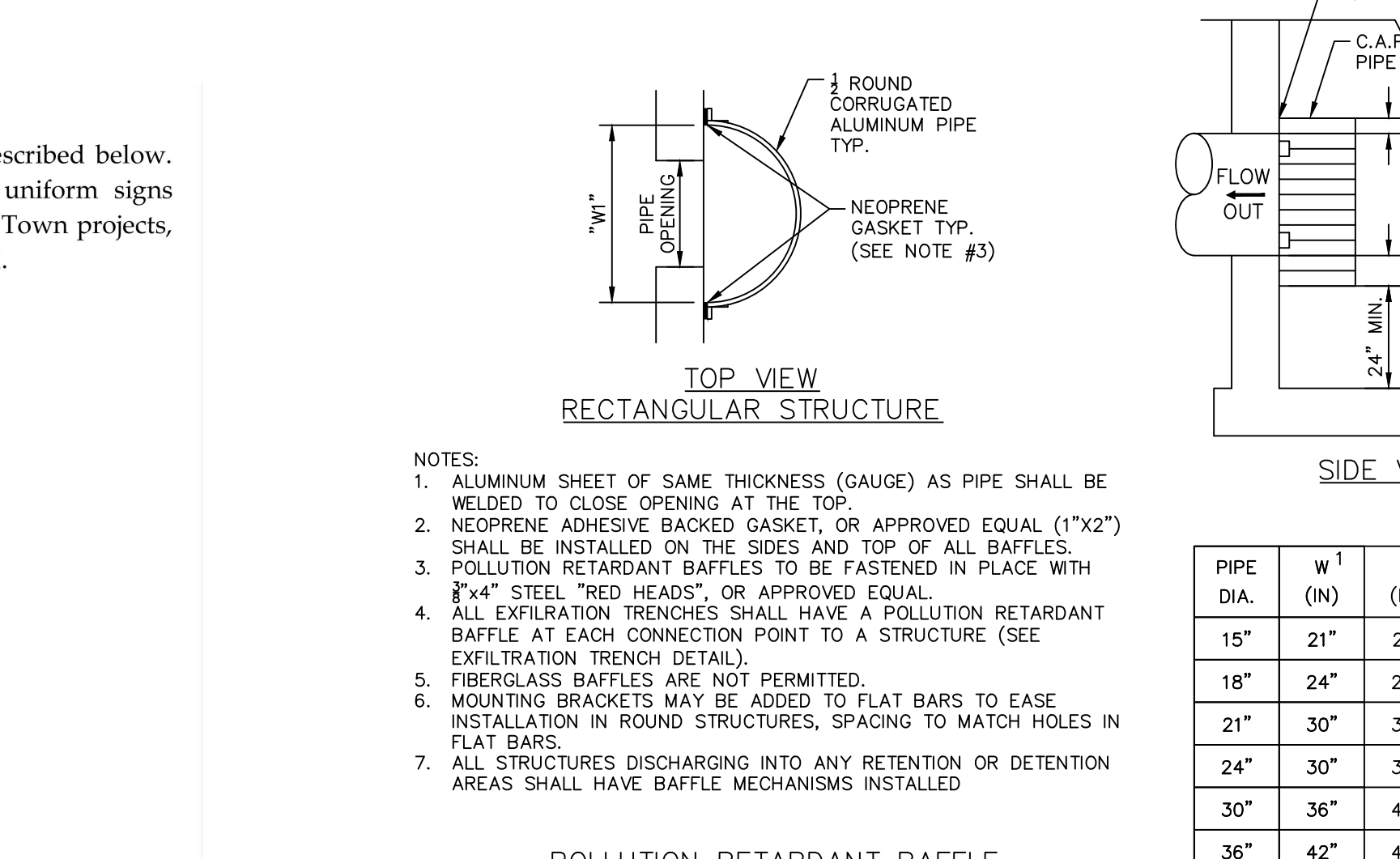

TABLE OF SIDEWALK JOINTS	
LOCATION	LOCATION
A	P.C. AND P.T. OF CURVES, JUNCTION OF EXISTING AND NEW SIDEWALK.
B	5'-0" CENTER TO CENTER ON SIDEWALK.
C	WHERE SIDEWALK ABUTS CONCRETE CURBS, DRIVEWAYS, AND SIMILAR STRUCTURES

**NOTES:**  
 1. PLACE #10/10 6x6 WIRE MESH IN THE PORTION OF THE SIDEWALK THAT CROSSES THE DRIVEWAY ONLY.  
 2. STANDARD SIDEWALK TO BE 3000 PSI @ 28 DAYS  
 3. CONCRETE FOR SIDEWALK AT DRIVEWAYS AND LOADING ZONES SHALL BE 4000 PSI @ 28 DAYS (HEAVY DUTY)  
 4. CURE ALL CONCRETE WITH CLEAN SAND, PLASTIC MEMBRANE, OR OTHER APPROVED METHOD.  
 5. TOOLED JOINTS TO OCCUR AT INTERVALS EQUAL TO WIDTH OF SIDEWALK  
 6. SIDEWALK TO HAVE BROOM FINISH PERPENDICULAR TO PATH OF TRAVEL.  
 7. CONTRACTOR SHALL REPAIR AND RESTORE ALL AREAS WITHIN THE ABUTTING R/W DISTURBED DURING CONSTRUCTION TO A CONDITION EQUAL TO OR BETTER THAN EXISTING AT NO ADDITIONAL COST TO THE OWNER.  
 8. ALL DEMOLISHED SIDEWALKS AND ADDITIONS ARE TO BE REPLACED WITH CONCRETE SIDEWALK TO MATCH EXISTING AT NO ADDITIONAL COST TO THE OWNER.  
 9. ALL DEMOLISHED SIDEWALK RAMP ARE TO BE REPLACED AS PER ADA STANDARDS AND INCLUDE ADA COMPLIANT DETECTABLE WARNINGS AT NO ADDITIONAL COST TO THE OWNER.



**NOTES:**  
 \* PROJECT SIGN LANGUAGE TO BE APPROVED BY TOWN



PIPE DIA.	W <sup>1</sup> (IN)	W <sup>2</sup> (IN)	T (GAUGE)	H (IN)
15"	21"	21"	16	VARIES
18"	24"	24"	16	VARIES
21"	30"	30"	16	VARIES
24"	30"	36"	16	VARIES
30"	36"	42"	14	VARIES
36"	42"	48"	14	VARIES
42"	48"	54"	14	VARIES
48"	54"	60"	14	VARIES
54"	60"	66"	14	VARIES

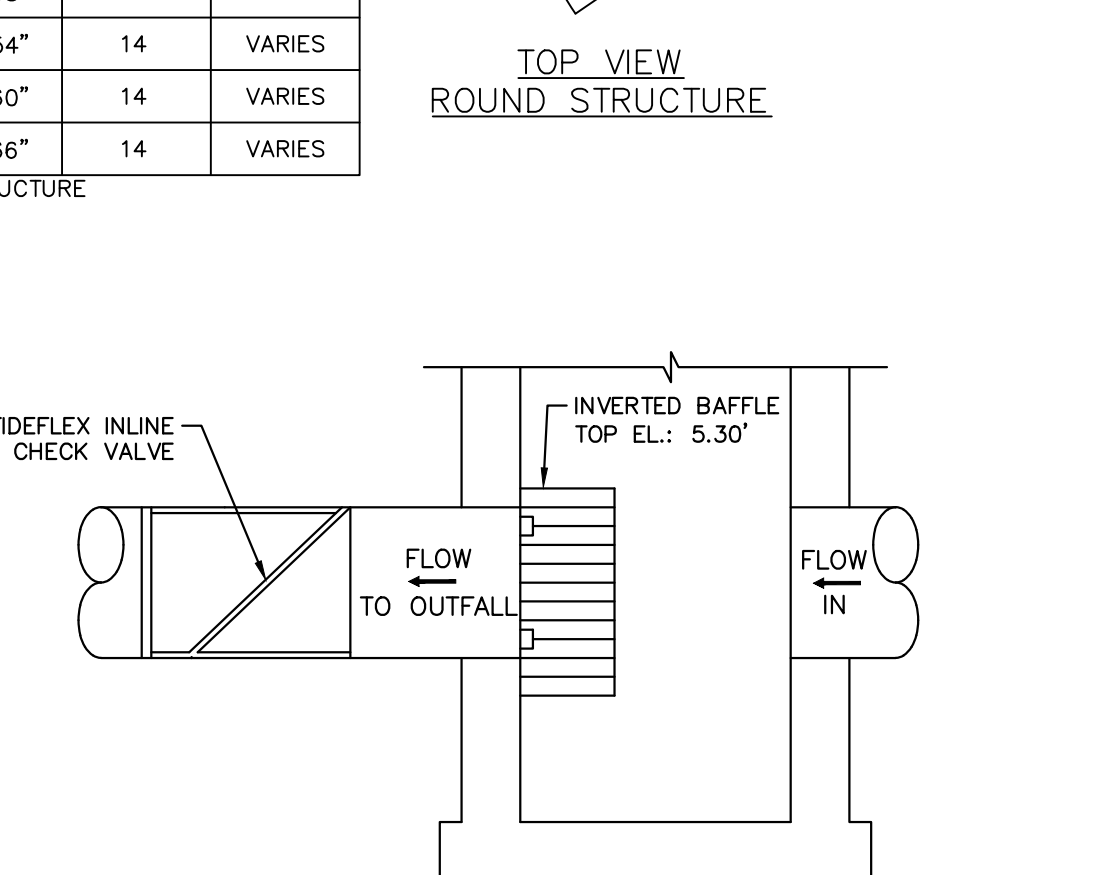
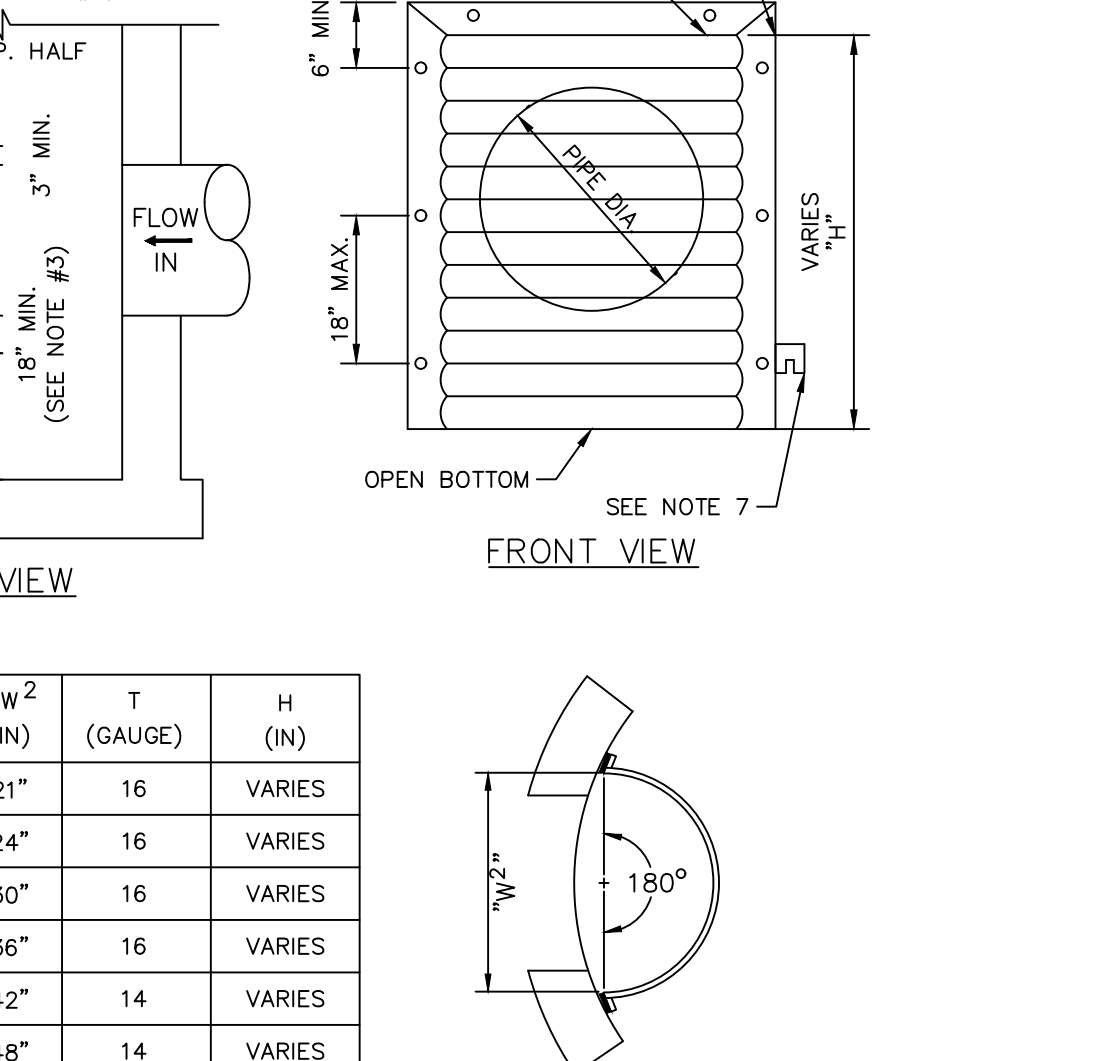
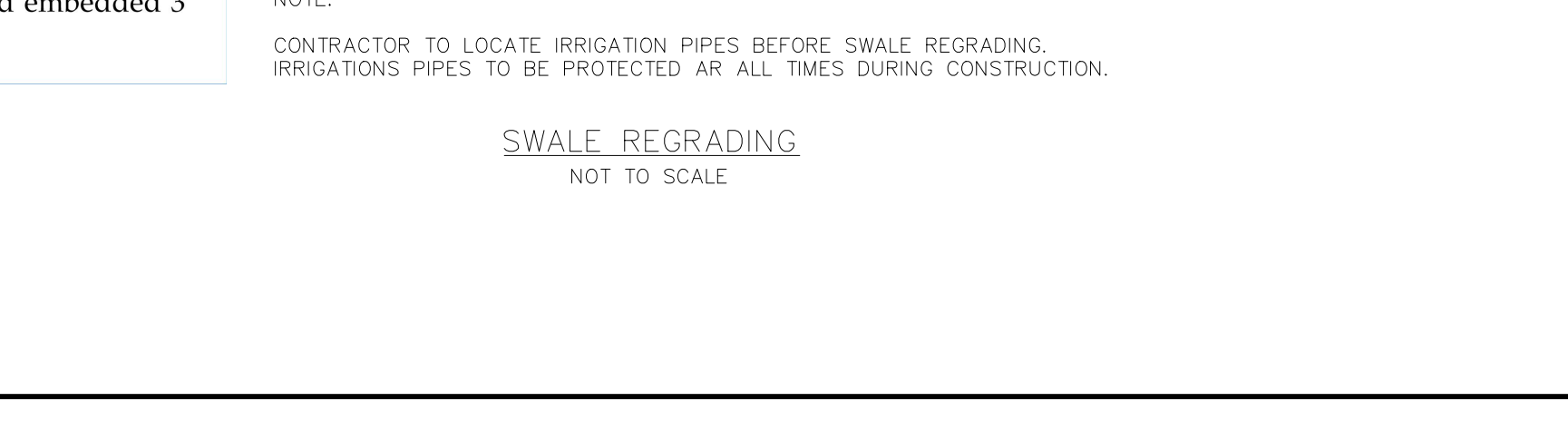

**NOTES:**  
 1. SEE PLAN VIEW FOR PIPE INVERTS AND SIZES

NO.	REVISIONS	DATE
1	DEMOS & PGD UPDATES	6/25/2024

**Kimley»Horn**  
 © 2024 KIMLEY-HORN AND ASSOCIATES, INC.  
 8201 PETERS ROAD, SUITE 2200, PLANTATION, FL 33324  
 PHONE: 954-535-5100 FAX: 954-739-2247  
 WWW.KIMLEY-HORN.COM  
 REGISTRY No. 35106

LICENSED PROFESSIONAL  
 TIFANY STANTON, P.E.  
 KHA PROJECT 044533222  
 DATE JUN 2024  
 SCALE AS SHOWN  
 DESIGNED BY TS  
 DRAWN BY DC  
 CHECKED BY SV  
 DATE: 6/25/2024

**PAVING GRADING AND DRAINAGE DETAILS**

**LOCH LOMOND NORTH DRAINAGE IMPROVEMENTS PREPARED FOR TOWN OF MIAMI LAKES**  
 SHEET NUMBER C301.3